



Beta 1-8 LSCbasic

Part no. 102420, 102422, 102424, 102426, 102428, 102430

Beta 2-8 LSCbasic

Part no. 102421, 102423, 102425, 102427, 102429, 102431



Freeze-dryer

Operating Manual

Please retain for later use!

In case of inquiries, please state the following numbers:

Order number:

Serial number:

© Copyright by
Martin Christ Gefriertrocknungsanlagen GmbH
An der Unteren Söse 50
37520 Osterode am Harz
Germany
Tel.: +49 (0) 5522 / 5007-0
Fax: +49 (0) 5522 / 5007-12
Web: www.martinchrist.de
E-mail: info@martinchrist.de

1	General information	9
1.1	Importance of the operating manual	9
1.2	Intended use	9
1.3	Warranty and liability	10
1.4	Copyright	10
1.5	Explanation of symbols	10
1.6	Standards and regulations	10
1.7	Scope of supply	11
2	Layout and mode of operation	12
2.1	Layout of the freeze-dryer	12
2.1.1	Functional and operating elements	12
2.1.2	Name plate	14
2.2	Mode of operation	15
2.2.1	General information on freeze-drying	15
2.2.2	Freeze-drying process	18
2.2.2.1	Preparation	18
2.2.2.2	Freezing	18
2.2.2.3	Main drying	19
2.2.2.4	Final drying	19
2.2.2.5	End of drying and aeration	19
2.2.2.6	Defrosting	20
3	Safety	21
3.1	Marking of the unit	21
3.2	Explanation of the symbols and notes	22
3.3	Responsibility of the operator	23
3.4	Operating personnel	23
3.5	Informal safety notes	24
3.6	Safety notes concerning the transport, set-up and connection and initial start-up of the freeze-dryer	24
3.6.1	General hazards	24
3.6.2	Hazards caused by improper transport	24
3.6.3	Hazards caused by improper set-up	25
3.6.4	Hazards caused by improper connection	25
3.7	Safety notes concerning the operation	26
3.7.1	Hazards caused by electricity	26
3.7.2	Hazards caused by the refrigeration system (natural, flammable refrigerants)	26
3.7.3	Hazards caused by the refrigeration system (non-flammable refrigerants)	27
3.7.4	Hazards caused by harmful products	28
3.7.5	Hazards caused by acids in the products	28
3.7.6	Hazards caused by contaminated condensate (defrosting water)	28
3.7.7	Hazards caused by hot surfaces	29
3.7.8	Hazards caused by cold surfaces	29

Table of contents

3.8	Safety devices	29
3.8.1	System check	29
3.8.2	Earth conductor check	29
3.9	Procedures in the event of hazards and accidents	30
3.10	Maintenance and cleaning of the freeze-dryer	30
3.11	Measures to be taken to ensure safe operation of the freeze-dryer	31
3.12	Remaining hazards	32
4	Storage and transport	33
4.1	Dimensions and weight	33
4.2	Storage conditions	33
4.3	Notes on transport	34
4.4	Packaging	35
4.5	Transport safety devices	35
5	Set-up and connection	36
5.1	Location of use	36
5.2	Power supply	37
5.2.1	Connection	37
5.2.2	Customer-provided fuses	37
5.3	Aeration valve	37
5.4	Media drain valve	38
5.5	Vacuum sensor	38
5.6	Vacuum pump	40
5.7	Pressure control valve	41
5.8	Rubber valves	42
6	Operation	43
6.1	Initial start-up	43
6.2	Installation of accessories	43
6.3	Preparation	43
6.4	Switching the freeze-dryer on	43
6.5	LSCbasic control system	44
6.5.1	User interface	44
6.5.1.1	Main window "Process"	45
6.5.1.2	Main window "Options"	53
6.5.1.3	Main window "?"	63
6.5.2	Starting a freeze-drying process	63
6.5.2.1	Entering set values	64
6.6	Optional extensions	66
6.7	Switching the freeze-dryer OFF	66

Table of contents

7	Malfunctions and error correction	67
7.1	General malfunctions.....	67
7.1.1	Power failure.....	68
7.1.2	Insufficient vacuum.....	69
7.1.2.1	Small flange connections.....	69
7.1.2.2	Aeration valve, media drain valve.....	70
7.1.2.3	Pressure control valve.....	70
7.1.2.4	Rubber valves.....	70
7.1.2.5	Vacuum sensor.....	70
7.1.3	Insufficient ice condenser temperature.....	71
7.2	Process and error messages.....	71
7.3	Service contact.....	72
8	Maintenance and service	73
8.1	Maintenance.....	73
8.1.1	General.....	73
8.1.2	Ice condenser chamber.....	74
8.1.3	Aeration valve, media drain valve.....	74
8.1.4	Heat exchanger (only for air-cooled freeze-dryers).....	75
8.1.5	Vacuum pump.....	75
8.1.6	Exhaust filter (oil mist separator).....	76
8.1.7	Vacuum sensor.....	76
8.1.8	Accessories.....	76
8.2	Disinfection of the drying chamber and accessories.....	77
8.3	Service.....	78
8.4	Return of defective parts.....	78
9	Disposal	80
9.1	Disposal of the freeze-dryer.....	80
9.2	Disposal of the packaging.....	80
10	Technical data	81
10.1	Ambient conditions.....	82
10.2	Technical documentation.....	82
11	Appendix	83
11.1	Brief operating instructions.....	83
11.2	EC declaration of conformity in accordance with the EC Machinery Directive.....	89
11.3	Declaration of conformity – China RoHS 2.....	91
11.4	EC declaration of conformity in accordance with the Pressure Equipment Directive.....	93
11.5	Resistance to stress cracking and chemical influences "Plexiglas".....	95
12	Glossary	113
13	Index	115

Table of contents

1 General information

1.1 Importance of the operating manual

A fundamental requirement for the safe and trouble-free operation of the unit is to be familiar with the fundamental safety instructions and all possible hazards.

The operating manual includes important information concerning the safe operation of the freeze-dryer.

This operating manual, and in particular the notes on safety and hazards, must be observed by all persons operating the unit.

In addition, the local rules and regulations for the prevention of accidents must be complied with.

1.2 Intended use

The freeze-dryer has been exclusively designed for the freeze-drying of solid or liquid products in ampoules, vials or dishes. It is, therefore, solely intended for this application.

The freeze-dryer is suitable for freeze-drying solid substances and aqueous solutions (e.g. bacteria and virus cultures, blood plasma, serum fractions, antibodies, sera, vaccines and pharmaceutical products such as chloramphenicol, streptomycin, vitamins, ferments and plant extracts for biochemical tests).

Freeze-drying of acid-containing products

Freeze-drying of products containing acids is only permissible if special protective measures and equipment-related precautions are taken. Otherwise, there is a risk of damage to property and personal injury. Consultation of Martin Christ Gefriertrocknungsanlagen GmbH is absolutely mandatory in order to define the measures that need to be taken!

Any other use beyond this area of application is regarded as improper use. Martin Christ Gefriertrocknungsanlagen GmbH cannot be held liable for any damage resulting from such improper use.

Any other use beyond this area of application is regarded as improper use. Martin Christ Gefriertrocknungsanlagen GmbH cannot be held liable for any damage resulting from such improper use.

The following operations are regarded as **NOT PERMISSIBLE**:

- operation of the freeze-dryer if it is not properly installed
- use of the freeze-dryer if it is not in a perfect technical state
- use of the freeze-dryer within hazardous locations where there is a risk of explosions
- use of the freeze-dryer with unauthorised additions or conversions without the written approval by Martin Christ Gefriertrocknungsanlagen GmbH
- use of the freeze-dryer with accessories that have not been approved by Martin Christ Gefriertrocknungsanlagen GmbH, with the exception of commercially available freeze-drying vessels made of glass or plastic

1 General information

- freeze-drying of products that may react during the freeze-drying process following the supply of high amounts of energy, e.g. solvent-containing products
- freeze-drying of explosive or flammable products
- freeze-drying of products that may damage the material of the chamber walls, shelves, pipes, or seals, or that may affect the mechanical strength

The intended use also includes:

- observation of all the notes and instructions included in the operating manual
- compliance with the inspection and maintenance instruction.

1.3 Warranty and liability

The warranty and liability are subject to our "General Terms and Conditions" that were distributed to the operator upon the conclusion of the contract.

Warranty and liability claims are excluded if they are due to one or several of the following reasons:

- improper use
- non-compliance with the safety instructions and hazard warnings in the operating manual
- improper installation, start-up, operation, and maintenance of the freeze-dryer.

1.4 Copyright

The copyright concerning the operating manual remains with Martin Christ Gefriertrocknungsanlagen GmbH.

The operating manual is solely intended for the operator and their personnel. It includes instructions and information that may not be

- duplicated,
- distributed, or
- communicated in any other way neither in full nor in parts.

Non-compliance may be prosecuted under criminal law.

1.5 Explanation of symbols

In this operating manual, specialist terms that are explained in the glossary (see chapter 12 - "Glossary") are marked by an arrow and printed in italics (e.g. → *sublimation*).

1.6 Standards and regulations

EC declaration of conformity in accordance with the EC Machinery Directive (see chapter 11.2 - "EC declaration of conformity in accordance with the EC Machinery Directive")

1.7 Scope of supply

The scope of supply comprises:

- 1 tube of high-vacuum grease
- 1 litre of vacuum pump oil (only if a pump is included)
- 1 set of flange components and several small parts for service and maintenance purposes
- 1 drain hose 0.5 m (silicone 8 x 12 mm)
- 1 operating manual

Accessories and commissioning

According to your order, our order confirmation, and our delivery note.

2 Layout and mode of operation

2 Layout and mode of operation

2.1 Layout of the freeze-dryer

2.1.1 Functional and operating elements

- 1 Ice condenser chamber
- 2 LSCplus user interface (see chapter 6.5.1 - "User interface")
- 3 Mains power switch



Fig. 1: Total view of the freeze-dryer

- 4 Pipe connection of the vacuum sensor
- 5 Pipe connection of the vacuum pump (behind the cover plate)
- 6 Ice condenser

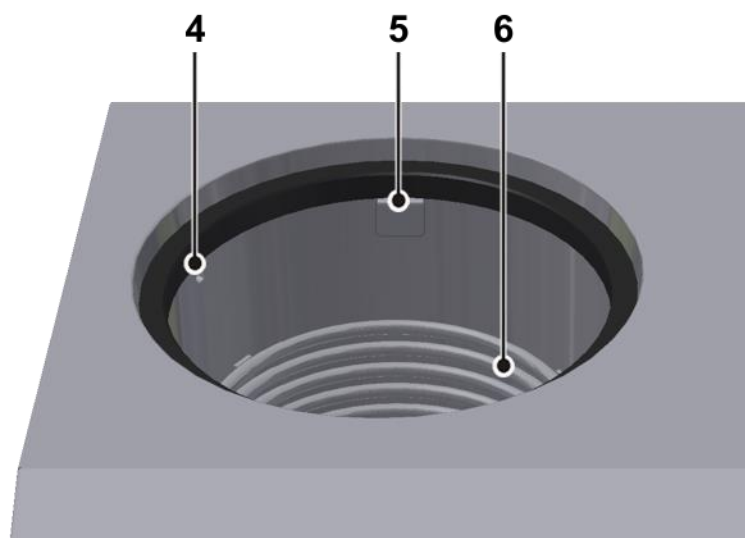

Fig. 2: Ice condenser chamber

2 Layout and mode of operation

- 7 Aeration valve
- 8 Media drain valve

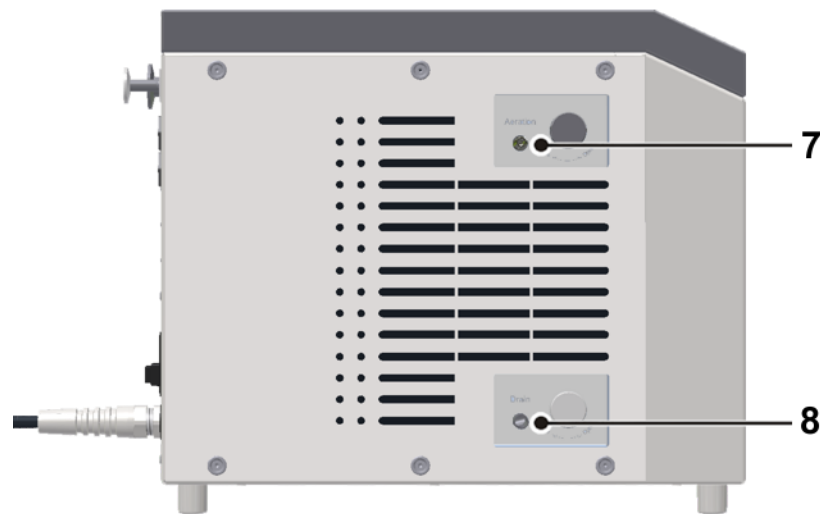

Fig. 3: Left side of the freeze-dryer

- 9 Touchpanel



Fig. 4: User interface with touchpanel

2 Layout and mode of operation

- 10 Heat exchanger of the refrigeration unit
- 11 Name plate (see chapter 2.1.2 - "Name plate")
- 12 Vacuum connection
- 13 Serial interface
- 14 Electrical connection of the vacuum sensor
- 15 Connection of the vacuum sensor
- 16 Power supply of the pressure control valve
- 17 Power supply of the vacuum pump
- 18 Mains fuse
- 19 Mains cable
- 20 Equipotential bonding screw

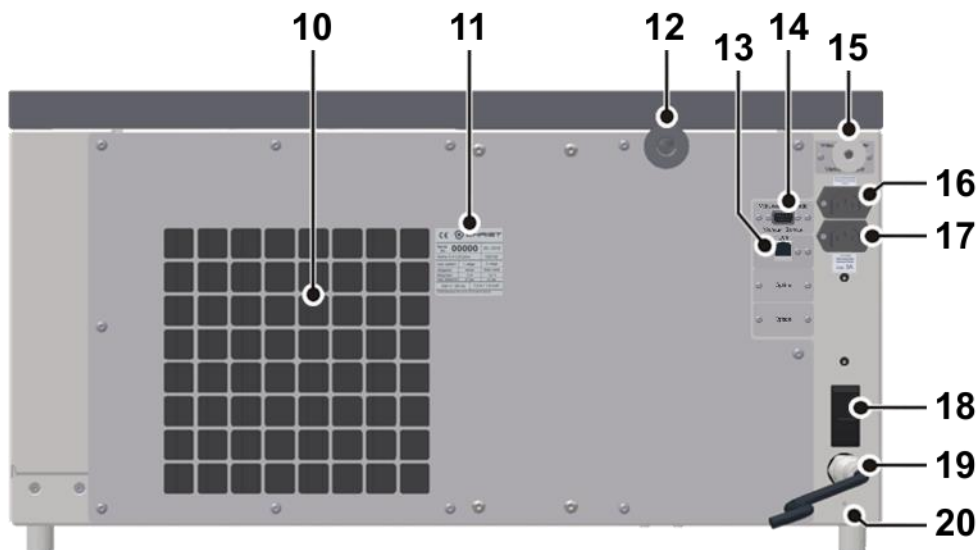

Fig. 5: Rear view of the freeze-dryer

2.1.2 Name plate

- 1 Serial number
- 2 Type
- 3 Refrigerant data of the 1st stage
- 4 Nominal voltage
- 5 Year of manufacture (month/year)
- 6 Part number
- 7 Refrigerant data of the 2nd stage
- 8 Rated current / apparent power

	
1 Serial No. 00000	5 03/2018
2 Beta 2-8 LSCbasic	6 102421
3 cool. system	7 1. stage 2. stage
refrigerant	R404A R290 / R508
filling	230g 8g / 76g
max. pressure	25 bar 25 bar
max. temp.	120°C 120°C
4 230 V / 50 Hz	8 6.0 A / 1.3 kVA
D-37520 Osterode am Harz, An der Unteren Söse 50, Germany	

Fig. 6: Example of a name plate

2.2 Mode of operation

2.2.1 General information on freeze-drying

What is freeze-drying?

Freeze-drying or lyophilisation is a procedure for the gentle drying of high-quality products. The product is dried by → *sublimation* without passing through the liquid phase.

What are typical applications for freeze-drying?

An important area of application is the drying of biotechnological and pharmaceutical products, e.g. tissues and tissue extracts, bacteria, vaccines, and sera. Products that would not keep well when they are dissolved in water can be preserved by freeze-drying. During this process, the biological properties of these sensitive substances are preserved. The compounds remain unchanged from a qualitative and quantitative point of view. After the addition of water, the products will have the same characteristics as the original products.

How does freeze-drying work?

Freeze-drying is a very gentle procedure for the extraction of water from a product in the frozen state. The drying process takes place through → *sublimation*, i.e. the direct transition of a product from the solid phase to the gas phase. This happens under vacuum.

The following section describes the process of sublimation based on the example of water, since most products that are processed by freeze-drying are aqueous solutions. Their behaviour is based on identical fundamental principles.

The vapour pressure curve for ice and water (sublimation pressure curve) describes the phase transition as a function of the pressure and temperature. The higher the temperature is, the higher the vapour pressure.

- If the vapour pressure is higher than 6.11 mbar (A), water passes through all three phases: solid, liquid, and gas (see the illustration).
- At 6.11 mbar and 0.0098°C, the melting pressure curve, vapor pressure curve, and sublimation pressure curve meet in one point, the so-called triple point. In this point, all three phases coexist (simultaneously).
- If the vapour pressure is below 6.11 mbar (B) and energy is added, the ice will be directly converted into water vapour once the sublimation curve is reached. This transition is called “sublimation”. If thermal energy is added to pure ice with a temperature of less than –30°C at a pressure of 0.37 mbar, it will be converted into water vapour once it reaches –30°C (see figure).

The vacuum prevents the melting of ice when energy is added. If thermal energy is added to a frozen product under vacuum, thawing of the product will be prevented and the water that is contained within the product will be released in the form of water vapour.

2 Layout and mode of operation

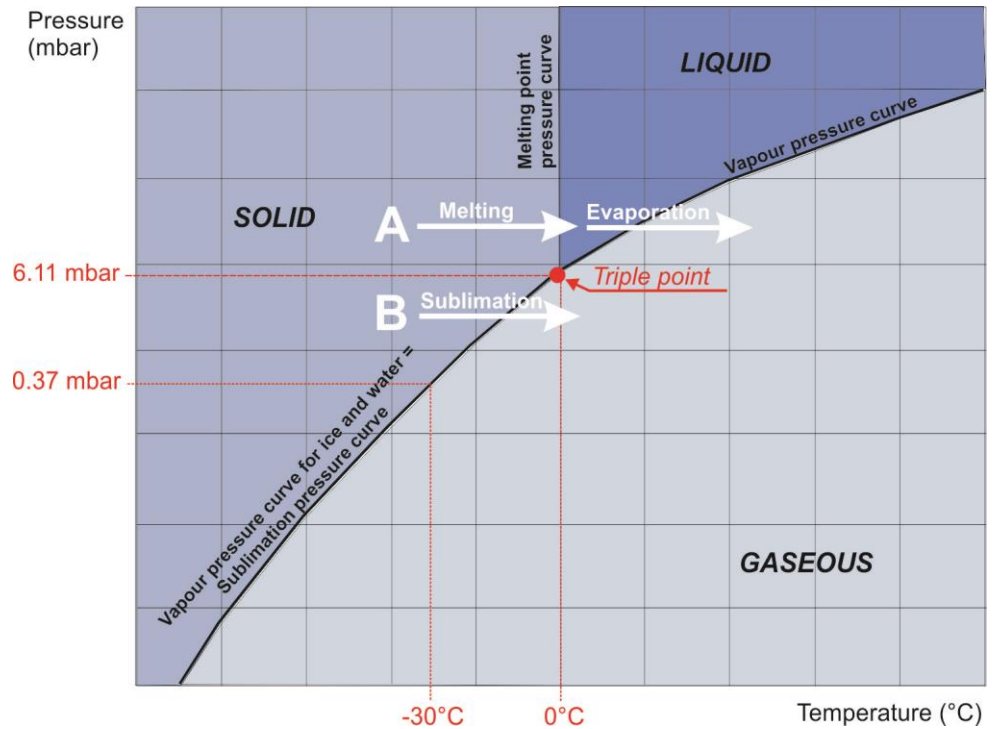

Fig. 7: Vapour pressure curve for ice and water (Sublimationsdruckkurve)

From a physical point of view, the freeze-drying process covers three phases (see figure below):

- (1) Freezing: The product to be dried is frozen under atmospheric pressure. This can be done either directly in the freeze-dryer or in a separate deep-freeze. The freezing temperature should be approximately 10°C below the solidification point of the product.
- (2) Evacuation: When the product is sufficiently frozen, the vacuum pump is activated. The pressure inside the drying chamber will be lowered to the value that corresponds to the freezing temperature in accordance with the vapour pressure curve for ice and water.
- (3) Sublimation: Thermal energy is added to the product, thus starting the sublimation process. Due to the added energy, the water in the product is converted into water vapour. Since the ice condenser is much colder than the product that is to be dried, the vapour pressure in the ice condenser is considerably lower than above the product. As a result, the water vapour that is released by the product streams to the ice condenser, where it condenses on the condenser coils.

Once the free water has been extracted from the product during the main drying phase, the last traces of bound water will also be removed at a final pressure that is as low as possible and at higher temperatures. This takes place by way of → *desorption*. This drying phase is also called final drying.

2 Layout and mode of operation

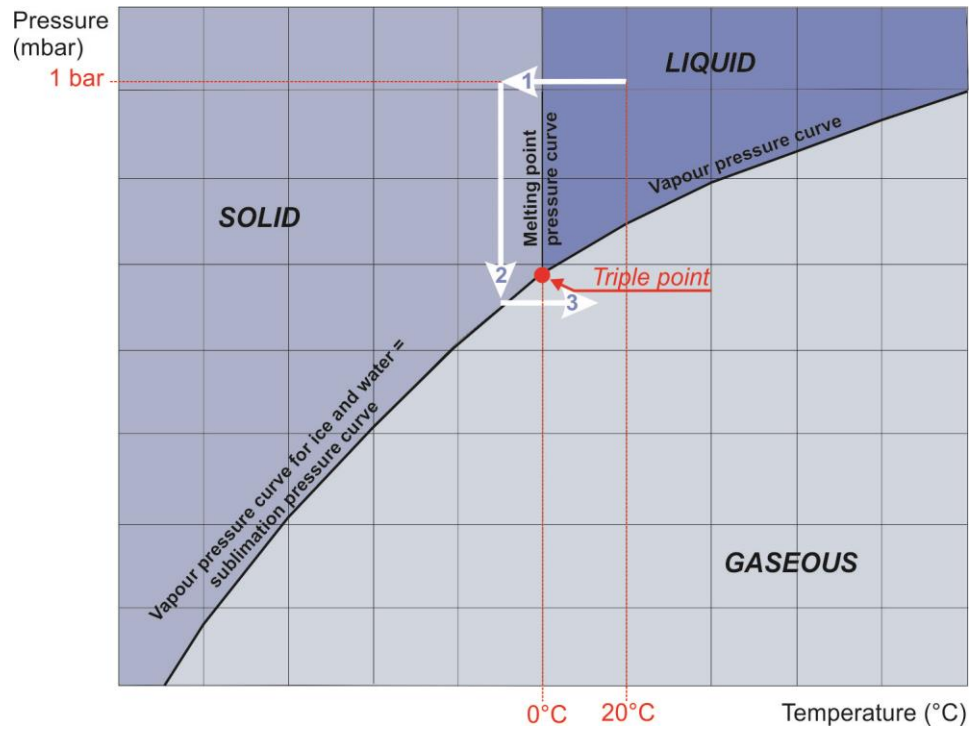

Fig. 8: Freeze-drying phases



NOTE

Please find further information about basic principles, optimum procedures and applications in the brochure "Smart freeze-drying", which can be downloaded at www.martinchrist.de → [Applications] → [Lyophilisation].

2 Layout and mode of operation

2.2.2 Freeze-drying process

The main components of a freeze-dryer are:

- vacuum drying chamber or drying manifold,
- vacuum pump for generating a vacuum inside the drying chamber,
- ice condenser for binding the water vapour that is released by the product.

2.2.2.1 Preparation

The ice condenser chamber must be clean and dry. Any water residues from a preceding drying run must be removed.

The media drain valve and the aeration valve must be closed.

In the case of units that are equipped with a pressure control valve (standard on LSCplus and LSCbasic units), the vacuum pump should be warmed up ("warm-up") for at least 15 minutes prior to the start of the main drying phase. Do not subject the vacuum pump to condensable gases until the operating temperature is reached. In this way, the service life of the vacuum pump can be extended.

At the same time, the ice condenser is pre-cooled ("cool-down"). The ice condenser temperature does not have any influence on the product temperature. The sole purpose of the ice condenser is to bind the released water vapour.

2.2.2.2 Freezing

First, the product that is to be dried is frozen. Especially in the case of small filling quantities, we recommend pre-cooling the shelves as well in order to prevent the product from thawing during the evacuation.

Two very different structures of the frozen material can be distinguished:

- crystalline structures with clearly distinguishable crystals
- amorphous structures with no crystal junctions at all (e.g. glass)

The majority of the freeze-drying products have a crystalline form.

When freezing these kinds of products, one must take into consideration that too deep and too quick freezing leads to smaller ice crystals, which has a negative effect on the duration of the drying process.

For every product to be dried, the solidification point must be determined as a first step. This is the point at which the water that is contained in the product has completely crystallised. In order to ensure an optimum freeze-drying process, the product temperature should be approximately 10°C below the solidification point.



If the product that is to be dried contains high salt concentrations, it may start to thaw during the drying process, which is indicated by clearly visible foaming. In order to prevent this, the product must be frozen as deeply as possible, e.g. with the aid of liquid nitrogen, prior to putting it into the unit.

2.2.2.3 Main drying

When the product is frozen, the main drying phase commences. The vacuum pump is switched on. The pressure inside the drying chamber will be lowered to the value that corresponds to the freezing temperature in accordance with the vapour pressure curve for ice and water (sublimation pressure curve). At the same time, thermal energy will be added to the product. In the case of products in round-bottom flasks, wide-neck bottles, etc., this is realised through the environment that is considerably warmer (direct contact heat), in the case of unheated shelves by way of thermal radiation from the environment, and in the case of temperature-controlled shelves directly via the shelves. As a result, the sublimation process starts. At the beginning of the drying process, the maximum drying rate will be reached. The more the sublimation area recedes into the product, the further the produced water vapour must pass through the layers that have already been dried.

Under certain conditions, it is possible that the vacuum inside the ice condenser chamber increases during the main drying phase (e.g. from 0.63 mbar to 0.47 mbar) although the valve towards the vacuum pump is closed. From a physical point of view, this is due to the pumping effect of the ice condenser ("cryo-pumping effect").

The required drying time depends strongly on the drying vacuum. At 1.0 mbar, one gram of ice takes up a volume of 1 m³ of vapour, at 0.1 mbar a volume of 10 m³ of vapour, and at 0.001 mbar a volume of 100 m³. The closer the vacuum is to the solidification point, the smaller is the resulting vapour volume. The drying rate increases and the drying time decreases.

2.2.2.4 Final drying

Final drying is an option whenever one requires a product with minimal residual moisture. In the physical sense, this process is a desorption process, i.e. the removal of adsorptively bound water. Final drying is performed under the lowest possible final pressure that depends on the ice condenser temperature in accordance with the vapour pressure curve for ice and water as well as on the final vacuum of the vacuum pump that is used. The process is supported by a higher shelf temperature.

2.2.2.5 End of drying and aeration

The end of the drying process is reached when both the product and shelf temperature are clearly in the positive range (+15 to +20°C) and if their difference is not greater than 5 K.

Another indication of the end of the drying process is the behaviour of the vacuum and of the ice condenser temperature. The ice condenser is no longer subject to load and reaches the final temperature of approximately -55°C or -85°C. The pressure in the drying chamber decreases in accordance with the ice condenser temperature.

The vacuum pump will be switched off and the drying chamber will be aerated via a rubber valve or via the aeration valve. The aeration valve can also be used to flood the unit with nitrogen or another inert gas instead of ambient air.

Then, the product can be removed from the unit.

2 Layout and mode of operation

2.2.2.6 Defrosting

Defrosting with hot gas













As standard, the freeze-dryer is equipped with a hot-gas defrosting system. In order to defrost the ice condenser, heated refrigerant is fed through the heating coil. In addition, the bottom of the ice condenser chamber is heated by way of a heating collar.

In order to avoid damage, the condensate must be drained off through the media drain valve directly after the completion of the defrosting process. Then, any residual water must be removed from the ice condenser chamber by way of a cloth.

3 Safety

3.1 Marking of the unit

The following symbols are used for Christ freeze-dryers:

	Dangerous voltage		On (Power)
	Hot surface		Off (Power)
	Caution! Risk of bruising		Name plate (see chapter 2.1.2 - "Name plate")
	Attention, consult the operating manual		Filled with natural inflammable refrigerants
	Protective earth (ground)		CE mark in compliance with the directive 2006/42/EC
	Earth (ground)		China RoHS 2 mark (only for China)
	Unplug the mains plug		

i
NOTE

Safety indications on the freeze-dryer must be kept readable at all times. If necessary, they must be replaced.

i
NOTE

Not all of the symbols/labels are used for this type of freeze-dryer.

3 Safety

3.2 Explanation of the symbols and notes

This operating manual uses the following names and symbols to indicate hazards:



This symbol stands for a **direct** hazard to the life and health of persons.

Non-observance of these symbols **causes** serious health problems up to life-endangering injuries.



This symbol stands for a **direct** hazard to the life and health of persons due to electrical voltage.

Non-observance of these symbols **causes** serious health problems up to life-endangering injuries.



This symbol stands for a **potential** hazard to the life and health of persons.

Non-observance of these symbols **can** cause serious health problems up to life-endangering injuries.



This symbol indicates a potentially hazardous situation

Non-observance of these notes can cause minor injuries or damage to property.



This symbol indicates important information.

3.3 Responsibility of the operator

The operator is obliged to ensure that the persons working with the freeze-dryer

- are 18 years old or older,
- have been specifically ordered to do so by the operator and that they have been duly informed about the specific hazards associated with the system, supply media and starting/final products as well as about the correct conduct and necessary measures to take in the event of accidents or malfunctions,
- are familiar with the fundamental regulations concerning workplace safety and accident prevention,
- have read and understood this operating manual (and in particular the safety sections and warning notes) and confirmed this with their signature.

The areas of responsibility of the personnel concerning the operation, maintenance, and care of the unit must be clearly defined.

The safety-conscious work of the personnel in compliance with the operating manual and the relevant EC and national health and safety regulations as well as with the accident prevention regulations must be checked at regular intervals (e.g. every month).

The operator is responsible for performing a risk assessment in terms of disasters (e. g. fire) in the working area and, if necessary, for taking constructional measures.

The operator is responsible to check the chemical compatibility of all substances to be used inside the freeze-dryer (product to be processed, cleaning media, etc.) with the material of the chamber walls, shelves, pipes, and gaskets. Substances that may damage the material and degrade the mechanical strength must not be used.

The freeze-dryer has to be maintained regularly (see chapter 8 - "Maintenance and service").

Components that are not in a perfect state must be replaced immediately.

3.4 Operating personnel

It must be ensured that persons operating the unit

- are 18 years old or older,
- have been specifically ordered to operate the unit and made aware of dangers originating from the freeze-dryer, supply media, starting and end products by the operator,
- be familiar with the fundamental regulations concerning workplace safety and accident prevention
- have been trained in terms of the operation of this unit, and
- have read and understood this operating manual (and in particular the safety sections and warning notes) and confirmed this with their signature.

3 Safety

3.5 Informal safety notes

This operating manual is part of the product.

- This operating manual must be kept at the location of use of the freeze-dryer. Ensure that it is accessible at all times.
- The operating manual must be handed over to every subsequent owner or user of the freeze-dryer.
- Any changes, additions or updates received must be added to the operating manual.
- In addition to the operating manual, the general and operational rules and regulations for the prevention of accidents and the protection of the environment must be provided.
- All of the safety and hazards notes on the freeze-dryer must be kept readable at all times. If necessary, they must be replaced.

3.6 Safety notes concerning the transport, set-up and connection and initial start-up of the freeze-dryer

The following notes and instructions must be observed in order to protect all persons and property.

3.6.1 General hazards



WARNING

General risk of injury

Among the general hazards during the transport, set-up and connection and start-up of the freeze-dryer are impact hazards, crushing hazards, grazing hazards, cutting hazards, etc.

This may lead to severe injuries.

- Comply with the fundamental health and safety rules and regulations as well as with the rules and regulations for the prevention of accidents!
- Wear personal protective equipment (safety shoes, work gloves, and hardhat)!

3.6.2 Hazards caused by improper transport



DANGER

Risk of injury caused by the uncontrolled movement of loads

Units that are not properly fastened or secured may shift, or fall over.

- Prior to transporting or setting-up the freeze-dryer, read the chapter 4 - "Storage and transport" thoroughly!

3.6.3 Hazards caused by improper set-up



WARNING

Risk of injury caused by poor accessibility of the freeze-dryer

In cramped spaces or locations with poor accessibility, sharp edges and corners may protrude into the work area.

This may lead to injuries caused by impact hazards or grazing hazards.

- Ensure that the freeze-dryer is set up freely accessible!
- Comply with the fundamental health and safety rules and regulations as well as with the rules and regulations for the prevention of accidents!

3.6.4 Hazards caused by improper connection



WARNING

Risk of injury caused by consequences of improper connection

Improper connection may lead to a hazardous electrical incident at a later time during the operation of the freeze-dryer.

This may lead to severe damage to health or even life-threatening injuries.

- Ensure that the local mains voltage matches the nominal voltage that is stated on the name plate.
- Do not place any dangerous material, e.g. glass vessels containing liquid substances, within the safety area of 30 cm around the freeze-dryer. Spilled liquids may get into the freeze-dryer and damage the electrical or mechanical components.
- Work on the power supply system must only be performed by certified electricians.
- Inspect the electrical equipment of the unit regularly. Defects such as loose or burnt cables must be eliminated immediately.

3 Safety

3.7 Safety notes concerning the operation

The following notes and instructions concerning the operation of the freeze-dryer must be observed in order to protect all persons and property.

3.7.1 Hazards caused by electricity



DANGER

Danger of life caused by electric shock

There is a risk of electric shock when touching current-carrying components.

This may lead to ventricular fibrillation, cardiac arrest, or respiratory paralysis.

- Only qualified electricians are authorised to perform work on the electrical system of the freeze-dryer!
- The electrical equipment of the freeze-dryer must be checked at regular intervals by a qualified electrician! Defects such as loose connections or burnt cables must be eliminated immediately.

3.7.2 Hazards caused by the refrigeration system (natural, flammable refrigerants)



DANGER

Risk of explosion due to refrigerants

The refrigerants used are highly flammable and can form an explosive mixture if their concentration in the ambient air is sufficiently high.

There is an explosion hazard.

- Work on the refrigeration system of the freeze-dryer must only be carried out by qualified specialist personnel who have been trained to handle flammable refrigerants!
- Ensure good ventilation and make sure that no ignition sources (e.g. soldering iron, welding equipment) are present!

3.7.3 Hazards caused by the refrigeration system (non-flammable refrigerants)**DANGER****Risk of suffocation caused by the refrigerant**

When work is performed on the refrigeration system of the freeze-dryer, refrigerant may escape in the liquid or gas state and under high pressure. Gaseous refrigerant is heavier than air and high concentration levels of it may collect on the floor or in pits.

There is a risk of suffocation in the case of high concentration levels. Possible symptoms are paralysis and unconsciousness. Affected persons do not notice the fact that they suffocate.

- Only qualified persons are authorised to perform work on the refrigeration system of the freeze-dryer!
- Ensure good aeration/extraction when working on the refrigeration system!

**WARNING****Risk of poisoning caused by the refrigerant**

During its decomposition (e.g. due to naked flames or hot surfaces), hazardous/toxic gases are released.

Contact with the decomposition products may cause severe damage to health.

- Only qualified persons are authorised to perform work on the refrigeration system of the freeze-dryer!
- Do not eat, drink, or smoke when working on the refrigeration system!

**WARNING****Risk of cold burns or frostbite caused by the refrigerant**

When work is performed on the refrigeration system of the freeze-dryer, refrigerant may escape in the liquid or gas state and under high pressure.

In the case of skin contact with liquid refrigerant, cold burns or frostbite may result.

- Only qualified persons are authorised to perform work on the refrigeration system of the freeze-dryer!

3 Safety

3.7.4 Hazards caused by harmful products



DANGER

Risk of poisoning/infection caused by the products

Operating personnel:

When loading and unloading the drying chamber, the personnel are exposed to the product.

Maintenance personnel:

When performing maintenance work on parts coming into contact with the product (e.g. all parts inside the chamber), the personnel may be exposed to product residues.

Skin contact or the inhalation of particles may cause severe damage to health depending on the product in question.

Operating personnel:

- Wear suitable protective clothes, gloves, and respiratory protection!

Maintenance personnel:

- Take suitable decontamination measures prior to commencing the maintenance!
- Wear suitable protective clothes and gloves!

3.7.5 Hazards caused by acids in the products



DANGER

Risk of injury caused by acids in the products

Products containing acids may damage the material of the components of the freeze-dryer and affect the mechanical strength.

This may lead to severe injuries.

Freeze-drying of products containing acids is only permissible if special protective measures and equipment-related precautions are taken! Consultation of Martin Christ Gefriertrocknungsanlagen GmbH is absolutely mandatory in order to define the measures that need to be taken!

- Refer to the safety data sheets of the products that are used!

3.7.6 Hazards caused by contaminated condensate (defrosting water)



WARNING

Risk of poisoning/infection caused by contaminated condensate (defrosting water)

The condensate may contain harmful substances originating from the product.

Contact with the condensate may cause severe damage to health.

- Ensure the environmentally sound disposal of the condensate in compliance with the local rules and regulations!
- Wear suitable protective clothes, gloves, and respiratory protection!

3.7.7 Hazards caused by hot surfaces



WARNING

Risk of burns on hot surfaces

After a drying process, some or all of the surfaces inside the chamber may still be hot.

There is a risk of burns when touching the surfaces.

- Wear suitable protective clothes and gloves!
- Do not touch the surfaces on purpose!

3.7.8 Hazards caused by cold surfaces



WARNING

Risk of freezing to cold surfaces

The ice condenser coils can already be cold during the loading phase.

There is a risk of freezing to the ice condenser coils when touching the surfaces.

- Wear suitable protective clothes and gloves!
- Do not touch the surfaces on purpose!

3.8 Safety devices

3.8.1 System check

An internal system check system monitors the data transfer and sensor signals with regard to plausibility. Errors are detected by continuous self-monitoring of the system. Error messages are displayed in the main window under "Process & equipment messages" (chapter 6.5.1.1 - "Main window "Process"", chapter 7.2 - "Process and error messages").

3.8.2 Earth conductor check

For the earth conductor check, there is an equipotential bonding screw on the rear panel of the freeze-dryer. An earth conductor check can be carried out with the aid of a suitable measuring instrument.

3 Safety

3.9 Procedures in the event of hazards and accidents

Hazardous electrical incident:

- Set the control switch to the "0" position in order to interrupt the power supply completely.

Fire:

- A fire in the electrical control system must be extinguished with a CO₂ fire extinguisher!
- Burning oil must be extinguished with a CO₂ fire extinguisher or powder fire extinguisher!

Electric shock:

- While ensuring your **own safety**, interrupt the circuit as quickly as possible (control switch). Keep the affected persons warm and calm. **Get medical attention immediately!** Check consciousness and breathing continuously. In the case of unconsciousness or lack of normal breathing, perform cardiopulmonary resuscitation (CPR).

Burns:

- Cool small-area burns (e.g. finger) immediately with cold water for approximately 2 minutes.
- Do not cool if larger areas of the body surface are burnt since there is a risk of hypothermia.
- Cover the burns loosely and in a sterile manner (e.g. with sterile dressing).
- Keep the affected persons warm and calm.

IF IN DOUBT, CALL THE EMERGENCY PHYSICIAN (AMBULANCE)!

3.10 Maintenance and cleaning of the freeze-dryer

The substances and materials that are used must be properly handled and disposed of (Please refer to the safety data sheets!). This applies particularly to

- the handling of solvents, lyes, and acids,
- the changing and topping-up of operating supplies.

Compliance with the national rules and regulations must be ensured.

3.11 Measures to be taken to ensure safe operation of the freeze-dryer

In order to ensure the safe operation of the freeze-dryer, please comply with the following points prior to every freeze-drying process:

Set-up, connection and operation

- Ensure that the freeze-dryer was set up and connected properly (see chapter 5 - "Set-up and connection").
- Check the freeze-dryer and the accessories before every start-up for any visible signs of damage.
- Do not hit or move the freeze-dryer during its operation.
- Do not lean against or rest on the freeze-dryer during its operation.
- Stop the freeze-dryer immediately in the event of a malfunction. Eliminate the malfunction (see chapter 7 - "Malfunctions and error correction") or contact the after-sales service of Firma Martin Christ Gefriertrocknungsanlagen GmbH (see chapter 7.3 - "Service contact").
- Ensure that all repairs are performed only by authorised and specialised personnel.

Fire prevention

- Fuses protect certain electrical circuits within the freeze-dryer against over-current conditions. Always use fuses of the same type and rating.

Safety area

- Maintain a safety distance of at least 30 cm (12 inches) around the freeze-dryer.
- Do not store any dangerous goods in the safety area of the freeze-dryer.
- Do not place any dangerous material, e.g. glass vessels containing liquid substances, within the safety area of 30 cm around the freeze-dryer. Spilled liquids may get into the freeze-dryer and damage the electrical or mechanical components.
- Do not stay in the safety area longer than what is absolutely necessary for the operation of the freeze-dryer.

Accessories

- Do not use the freeze-dryer with accessories that shows signs of damage.
- Only use accessories that have been approved by the manufacturer (except for commercial vessels made of glass or synthetic materials). We explicitly warn against the use of equipment of poor quality! Breaking glass or bursting vessels can cause dangerous situations.

3 Safety

3.12 Remaining hazards

All Christ freeze-dryers were built state-of-the-art and according to the accepted safety rules. Danger to life and limb of the operator, or of third parties, or impairments of the units or other material assets, however, cannot be completely excluded when the units are being used.

Use the freeze-dryer

- only for the purpose that it was originally intended for (see chapter 1.2 - "Intended use") and
- only if it is in a perfect running state.
- Immediately eliminate any problems that can affect safety.

4 Storage and transport

4.1 Dimensions and weight

Values for the freeze-dryer without a vacuum pump:

	Beta 1-8 LSCbasic	Beta 2-8 LSCbasic
Height:	415 mm	415 mm
Width:	780 mm	780 mm
Depth:	555 mm + 80 mm vacuum connection	555 mm + 80 mm vacuum connection
Weight:	approx. 63 kg	approx. 78 kg

4.2 Storage conditions

In order to ensure the protection against mechanical and climatic influences, the guidelines of the German Federal Association for Wooden Packages, Pallets, and Export Packaging (Bundesverband Holzpackmittel, Paletten, Exportverpackung e.V.), the so-called HPE packaging guidelines, must be applied when packing and storing the freeze-dryer.

The storage must be:

- dust-free
- dry
- free from excessive temperature fluctuations
- free from a mechanical load.

4 Storage and transport

4.3 Notes on transport

- Use suitable packaging for the transport, and if at all possible, the original packaging.
- Install all transport safety devices (see chapter 4.5 - "Transport safety devices").
- Over short distances, the freeze-dryer can be transported by a suitable number of persons who reach under it from the sides.
- When lifting the freeze dryer, always reach under the freeze-dryer from the side. Do not grab the unit at the plastic control panel (see figures below).

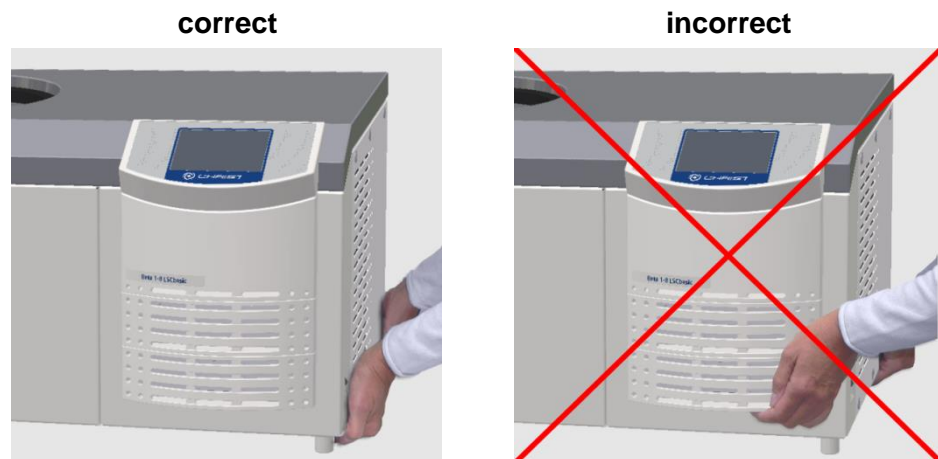

Fig. 9: Lifting the freeze-dryer



CAUTION

The freeze-dryer Beta 1-8 LSCbasic weighs approx. 63 kg!
The freeze-dryer Beta 2-8 LSCbasic weighs approx. 78 kg!



CAUTION

The centre of gravity of the freeze-dryer is off-centre!

- When setting the unit down, ensure that the feet are upright (see figures below).



Fig. 10: Unit feet

4.4 Packaging

The freeze-dryer is packaged in a wooden crate.

- After opening the packaging, take out the accessories.
- Remove the packaging material.
- Remove the side walls of the crate.
- Lift the freeze-dryer upwards and out of the crate/cardboard box. When lifting the unit, always reach under the freeze-dryer from the side.



CAUTION

The freeze-dryer Beta 1-8 LSCbasic weighs approx. 63 kg!
The freeze-dryer Beta 2-8 LSCbasic weighs approx. 78 kg!



CAUTION

The centre of gravity of the freeze-dryer is off-centre!

- Retain the packaging for any possible future transport of the freeze-dryer.

4.5 Transport safety devices

Prior to start-up, the vacuum sensor must be installed (see chapter 5.5 - "Vacuum sensor").



NOTE

Prior to any transport, the transport safety devices must be deinstalled.

5 Set-up and connection

5 Set-up and connection

5.1 Location of use

Use the freeze-dryer solely in closed and dry spaces.



NOTE

Refrigeration problems of the freeze-dryer are often caused by insufficient conditions at the location of use. This is why compliance with the following conditions is absolutely mandatory!

- The table must be stable and have a solid, even tabletop
- Ensure sufficient ventilation. Do not place any paper, cloth or similar material behind or under the unit, since otherwise the air circulation will be impaired.
- Keep a safety distance of at least 30 cm around the freeze-dryer so that the vents in the unit remain fully effective.
- The ambient temperature must be in the range of +10°C to +25°C. A potential night-time setback of the air conditioning system must be taken into consideration.
- Prevent the room temperature from rising, for example due to closed doors at night.
- Do not subject the freeze-dryer to thermal stress, e.g. by positioning it near heat generators.
- Prevent thermal overload, e.g. caused by other equipment in the direct vicinity of the freeze-dryer.
- Do not set up the vacuum pump in the area of the heat exchanger ventilation grid (see chapter 2.1.1 - "Functional and operating elements").
- In the case of water-cooled systems, ensure that the water circuit provides a sufficient amount of cooling water.
- Avoid direct sunlight (UV radiation).

5.2 Power supply

5.2.1 Connection



DANGER

The operating voltage on the name plate must correspond to the local supply voltage

Christ freeze-dryers are units of safety class I. Beta 1-8 LSCbasic and Beta 2-8 LSCbasic units have a three-wire power cord with a fixed cable (see chapter 10 - "Technical data").

An equipotential bonding screw is located on the back below the mains power input (see chapter 2.1.1 - "Functional and operating elements"). This equipotential bonding screw can be used to perform an earth conductor check.

5.2.2 Customer-provided fuses

Typically, the freeze-dryer must be protected with 16 Amp G fuses that are to be provided by the customer.

5.3 Aeration valve

The aeration valve is located on top of the left side of the unit (see chapter 2.1.1 - "Functional and operating elements").

After the end of a freeze-drying process, the unit will be aerated via the aeration valve.



NOTE

The ice condenser chamber can be flooded with nitrogen via the hose nozzle of the aeration valve.

5 Set-up and connection

5.4 Media drain valve

The media drain valve is located at the bottom of the left side of the unit (see chapter 2.1.1 - "Functional and operating elements").

It is used to drain off the condensate and the defrosting water.

- Connect the drain hose (included in the scope of supply) to the hose connector.
- Place a collecting vessel under the unit.

The hose must be laid with a continuous slope and the end of the hose must always be above the liquid level in the collecting vessel. This prevents water and dirt residues from being sucked into the ice condenser chamber if there is negative pressure when the media drain valve is opened.

5.5 Vacuum sensor



Please refer to the separate operating manual of the vacuum sensor!

In order to protect the vacuum sensor against transport damage, it comes supplied in its original packaging. Prior to commissioning the freeze-dryer, the sensor must be installed.

- 1 Vacuum sensor
- 2 Connection socket



Fig. 11: Position of the vacuum sensor and the connection socket

- Switch the unit off by actuating the mains power switch.
- Take the vacuum sensor out of its original packaging and fasten it to the connector with a bow-shaped connecting piece, two clamping rings (DIN16KF) and two centring rings (included in the scope of supply).
- Plug the connector to the connection socket and hand-tighten the screws on the connector.

i
NOTE

It is absolutely essential to comply with the manufacturer's instructions in the separate operating manual of the vacuum sensor!

Thyracont VCP63 (Pirani)



Pfeiffer CMR 363 (capacitive)



Fig. 12: Vacuum sensors of different manufacturers

i
NOTE

The vacuum sensor comes supplied in a calibrated state.

After the freeze-dryer has been switched on, the vacuum sensor needs several minutes until it is ready for operation.

5 Set-up and connection

5.6 Vacuum pump



NOTE

It is absolutely essential to refer to the separate instruction manual of the vacuum pump and exhaust filter (if applicable)!

The vacuum pump must be connected to the vacuum connection of the unit and to the electrical socket at the back of the unit, which is marked accordingly (see chapter 2.1.1 - "Functional and operating elements").



NOTE

The vacuum pump is supplied with power by the unit, but the maximum current for the vacuum pump is limited. It is absolutely essential to refer to the label of the electrical outlet for the vacuum pump (see the following picture)!

If the current requirement of the vacuum pump is higher than the value that is stated on the label, the pump must be supplied separately via an on-site power socket.

- 1 Label indicating the maximum current

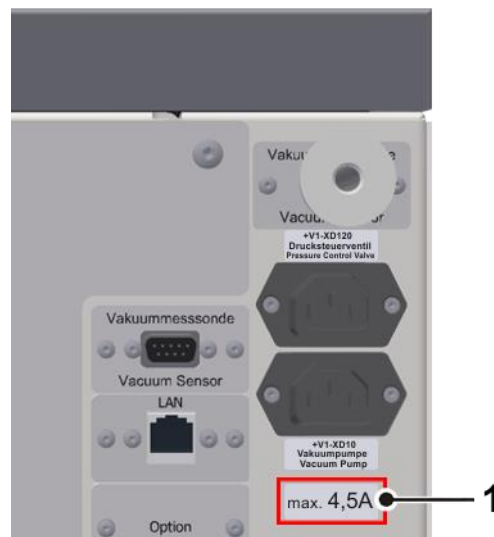

Fig. 13: Indication of the maximum current for the vacuum pump (example)

The oil mist that escapes from the pump during operation must be retained or discharged via an exhaust filter (oil mist separator).

- We strongly recommend using an oil mist separator. The filter prevents air pollution by the oil mist that is emitted more or less strongly by the pump depending on the working pressure.
- The exhaust gases must be discharged in a proper manner.
- The hose line must be laid in such a manner that any condensation water cannot flow back into the pump. In the case of a rising hose line, we recommend using a condensate trap (Woulff bottle or wash bottle).

5.7 Pressure control valve

The pressure control valve is integrated in the suction pipe between the vacuum pump and ice condenser chamber. During certain, specified process phases, it interrupts the volume flow to the vacuum pump (see chapter 2.2.1 - "General information on freeze-drying")



CAUTION

Observe the installation direction of the pressure control valve (see figure)!

- 1 Connection to the vacuum pump
- 2 Pressure control valve

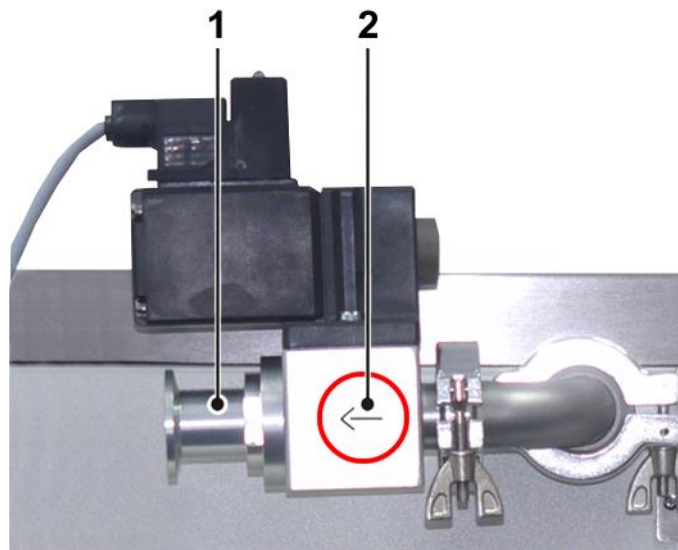

Fig. 14: Installation of the pressure control valve

5 Set-up and connection

5.8 Rubber valves

The rubber valves (part no. 121860) enable the connection of round-bottom flasks, wide-neck filter bottles, or distributors for ampoules to a manifold or drying chamber. Depending on the connector of the components, the blue plug can be removed.

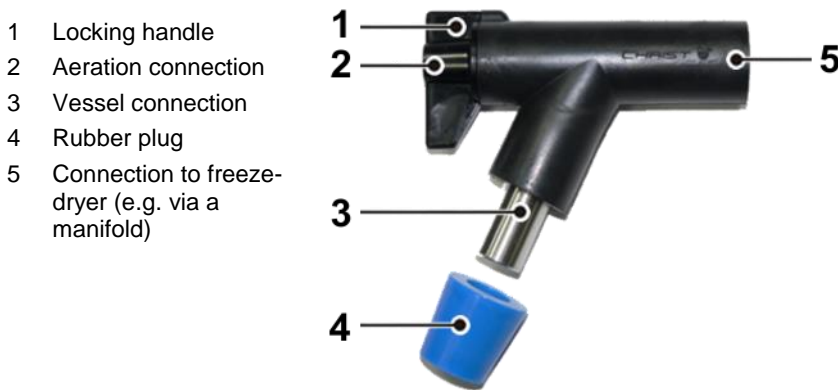

Fig. 15: Rubber valve



The rubber valves come supplied in an ungreased state. This is why a thin layer of vacuum grease must be applied to the connector of the freeze-dryer as well as to the vessel connector prior to start-up in order to ensure trouble-free operation.

In position A (see figure below), the aeration connector is open and the vessel connector is closed. The accessory will be aerated while the vacuum inside the drying chamber is maintained. As a result, vessels can be exchanged without any interruption of the drying process.

In position B, the aeration connector is closed and the vessel connector is open. The connected accessory is connected to the freeze-dryer.

In position C, the aeration connector and the vessel connector are closed.

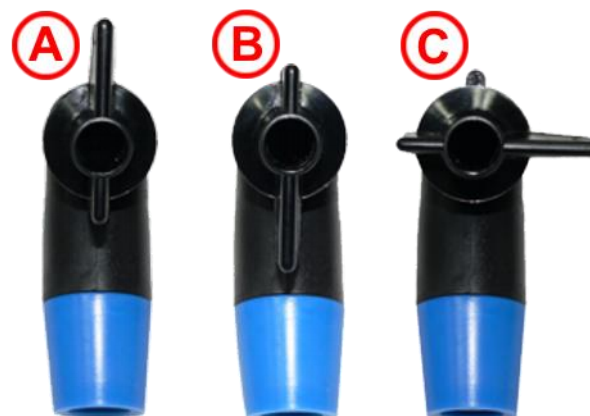

Fig. 16: Possible positions of the locking handle

6 Operation

6.1 Initial start-up



WARNING

Before the initial start-up, please ensure that your freeze-dryer is properly set up and installed (see chapter 5 - "Set-up and connection")

6.2 Installation of accessories

The accessories must be completed in accordance with the drying method that is applied as well as in accordance with the scope of supply.

6.3 Preparation

The ice condenser chamber must be clean and dry.

- Remove any water residues from the preceding run.
- Close the aeration valve and the media drain valve.
- Ensure that all of the valves of the accessories are closed.
- Switch the vacuum pump on.

6.4 Switching the freeze-dryer on

- Actuate the mains switch.

The control unit performs a self-test and an initialisation. This may take several seconds.

- Follow the safety instructions and hazard warnings (see chapter 3 - "Safety")!

6 Operation

6.5 LSCbasic control system

The control system LSCbasic (Lyo Screen Control basic) was specifically developed for the control of freeze-drying processes. The clear user interface enables the intuitive operation of the unit.



Fig. 17: Start screen of the LSCbasic control unit (example)

6.5.1 User interface

The system is operated via a touch panel, i.e. by touching the buttons on the display. Every button is marked by a frame. Pressing the button activates the associated function. Depending on the function, a dialogue box opens, a value can be changed, or a transaction can be confirmed.

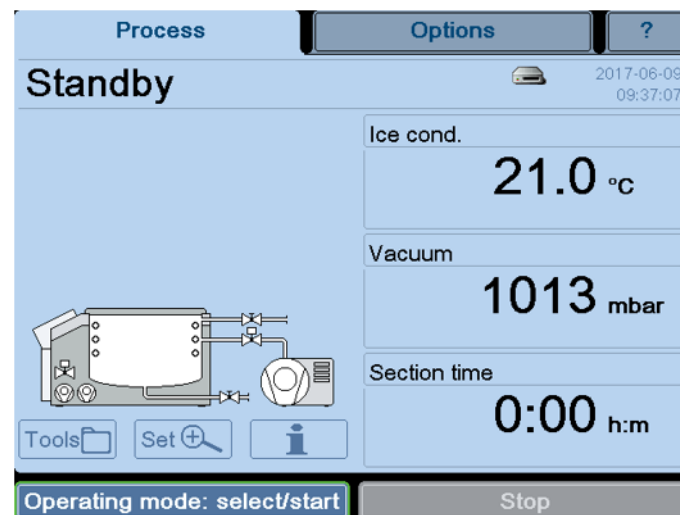

Fig. 18: User interface LSCbasic

The user interface is divided into three main windows that can be called up by touching the corresponding buttons:

Process

This window is also the standard user interface. It is used to control the freeze-drying process manually.

Options

This window is used for personalised settings that enable the users to adapt the system as far as possible to their respective area of activity.

?

In this window, the users can find all of the relevant information concerning the control system at a glance. In the event of enquiries at the factory, these data facilitate the assignment and expediting of the processing of the enquiries.

6.5.1.1 Main window "Process"

This main window shows all of the relevant process data. Here, the individual phases of a freeze-drying process can be controlled manually.

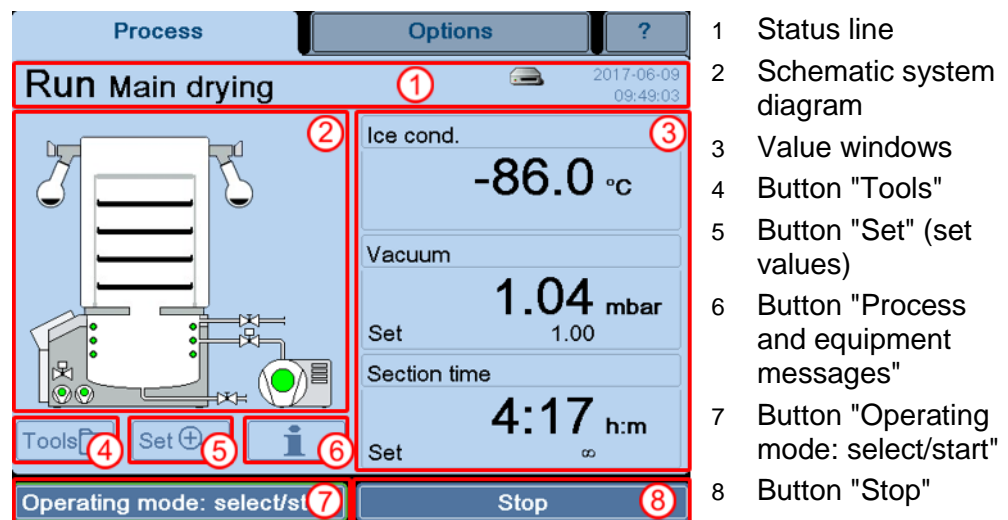

Fig. 19: Overview of the main window "Process"





Status line (1)

This line shows the operating status of the freeze-dryer as well as the active phase.

The status line also shows the current date and time. The clock is battery-buffered and must be reset after a failure (chapter 6.5.1.2 - "Main window "Options"", section "Administration").

In addition, the drive symbol provides information concerning the status of the external data storage device or of the network drive. The following symbols are possible:

6 Operation

No symbol	No USB storage device or LAN network connected
	USB storage device connected
	Active process recording on a USB storage device
	Network available, but no network drive connected
	Network drive connected (e.g. LyoLogplus)
	Network drive connected and active process recording

Button "Schematic system diagram" (2)

The left side of the user interface shows a schematic view of the system including all of its components. Active components are displayed in green. Touching a component calls up its name and → *reference designation*.

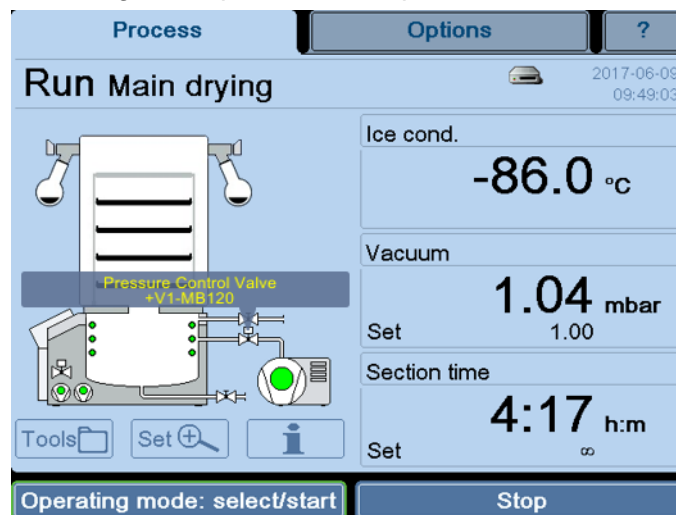

Fig. 20: Schematic system diagram with the name and reference designation of the component

Value windows (3)

This area shows the current process data. The three value windows can be configured as desired.

- Select the button of the value window that is to be adapted. A dialogue box with the possible parameters opens:
 - Total time (duration of the entire freeze-drying process up to this moment)
 - Section time (duration of the current section up to this moment)
 - Ice condenser (temperature of the ice condenser)
 - Vacuum (value of the vacuum inside the ice condenser chamber)
 - Temperature \triangleq vacuum (conversion of a vacuum value into a temperature value based on the vapour pressure curve for ice and water)

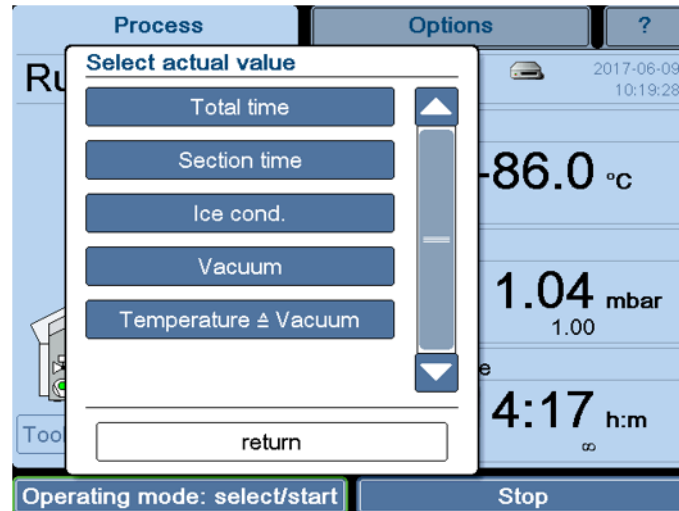

Fig. 21: Dialogue box "Select actual value"

- Select the desired configuration or exit the dialog box by pressing the "return" button.

In this way, it is possible to configure a personalised overview of the actual values.

Dialogue box "Tools" (4)

This dialog box is used to call up various aids and resources.

Vapour pressure curve for ice and water

A diagram shows the relationship between the pressure and sample temperature. The pressure and temperature values can be changed by way of the buttons or by moving the arrows (see item 1 in the screenshot). The other value will be adapted automatically.

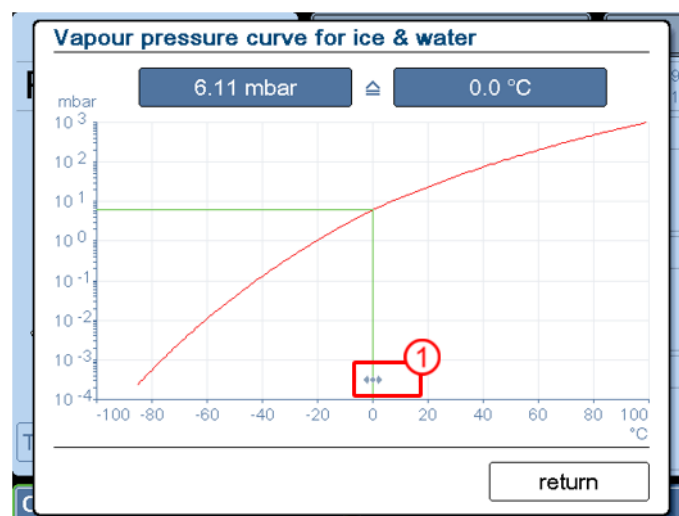

Fig. 22: Dialogue box "Vapour pressure curve for ice and water"

6 Operation

Option: USB process recording

(see chapter 6.6 - "Optional extensions")

- Select the "USB process recording" function in the dialogue box "Tools".
- Select the input fields ("Batch data"). A keyboard for the data input will be displayed.
- If necessary, select the "Options" tab, choose between manual or automatic recording, and define a recording interval.
- Press the "return" button in order to close the dialogue box.

The process recording will now run in the background.



Fig. 23: Dialogue box "USB process recording"

Option: Lifting hoist¹

(see chapter 6.6 - "Optional extensions")

This function is described in the separate operating manual of the lifting hoist.

Button "Set" (5)

This button is used to enter the set values for the individual phases of the freeze-drying process prior to the start of the process. Value ranges have been saved for the various phases. These value ranges can be displayed in the input window with the aid of the buttons "min" or "max" (see chapter 6.5.2.1 - "Entering set values").

Dialogue box "Process and equipment messages" (6)

This dialogue box is used to view and save all of the error messages and other messages. In the event of an error or message, the window "Process and equipment messages" will open automatically. In addition, a sound signal is emitted until the error is acknowledged.

¹ Not available for Alpha 3-4 LSCbasic

There are three categories of faults:

- Red: error messages
- Orange: process messages
- Yellow: general messages

The representation of the message provides information about its current status. A double frame around a message means that the error has not been eliminated yet. The colour of the button "quit" changes from blue to grey once the message has been acknowledged.



Fig. 24: Representation of an error message

The advantage of this system is that faults that occurred during the night can be discovered the next day even if the cause of the fault has already been eliminated.

The dialogue box cannot be quit until all of the messages have been acknowledged.

If a message has been acknowledged even though the fault has not been eliminated, the button "Process and equipment messages" will be displayed in the respective colour of the fault in the main window.

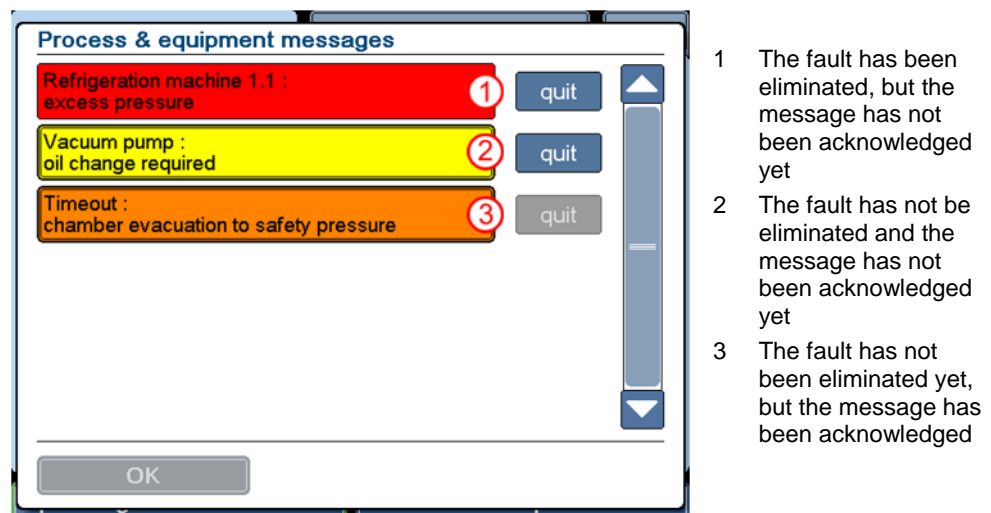

Fig. 25: Dialogue box "Process and equipment messages"

Details

Tapping the message displays details concerning the error message:

- Cause of the message
- Effects of the message
- Measures to eliminate the error
- → *Reference designation*
- Error counter (indicates how often this error has occurred) and the time stamp of the last error message.

6 Operation

Use the arrow buttons to open the individual windows.



The error message text is always followed by an error code. Always indicate the error code in the event of enquiries or service requests!

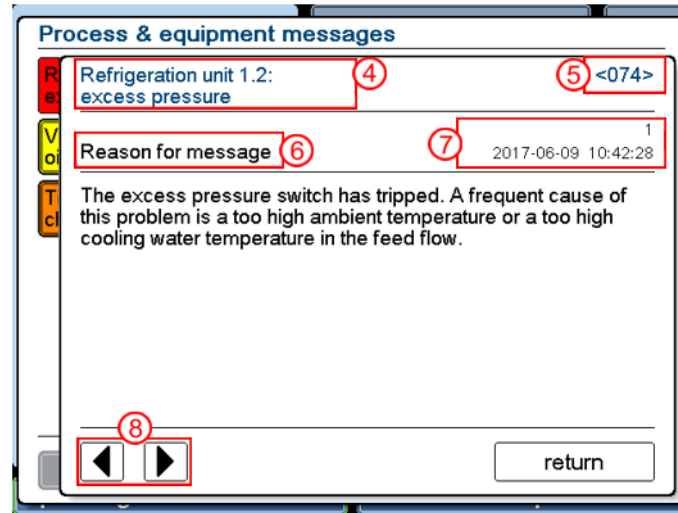

- 4 Error message
- 5 Error code
- 6 Detailed information
- 7 Error counter and time stamp of the last error
- 8 Arrow buttons

Fig. 26: Details concerning an error message



The texts of the process and error messages are not included in this operating manual.
The associated documents can be requested from our service department.

Dialogue box "Operating mode: select/start" (7)

After the set values have been entered for the process, the process can be started with this function (see chapter 6.5.2 - "Starting a freeze-drying process").

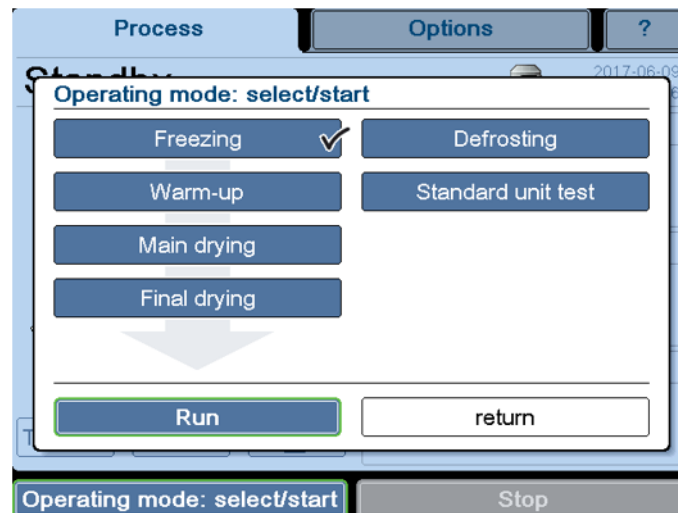

Fig. 27: Dialogue box "Operating mode: select/start" (The version of the dialogue box that is displayed depends on the equipment of the freeze-dryer.)

Button "Standard unit test"

Apart from the process phases of the freeze-drying process ("Freezing", "Warm-up", "Main drying" and "Final drying") and the operating mode "Defrosting", the button "Standard unit test" is also available. This button opens a selection of tests with fixed parameters. After consultation with the manufacturer, these tests can be performed in order to check the functionality and processes of the freeze-dryer.

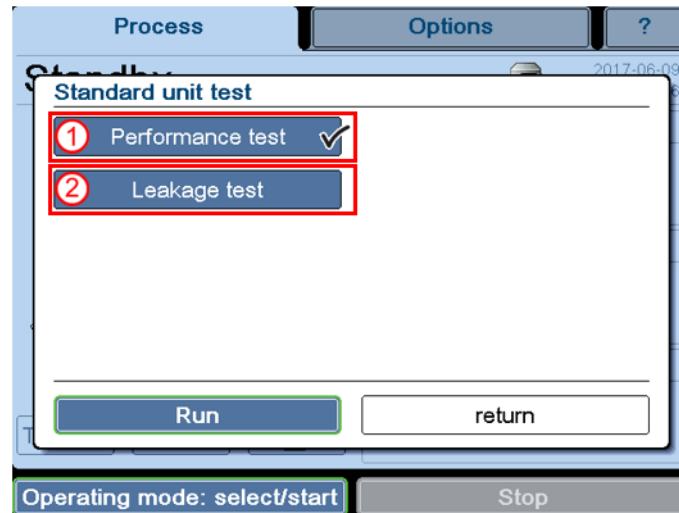

Fig. 28: Dialogue box "Standard unit test"

Performance test (1)

This test is used to determine the following performance parameters of a freeze-dryer:

- vacuum decrease rate
- final vacuum
- minimum ice condenser temperature



Prior to performing a test, ensure that the chamber is dry and unloaded and that the ice condenser is defrosted!

Procedure:

- In the main window "Process", select the button "Standard unit test" under "Operating mode: select/start".
- Select "Performance test" and start the test via the "Run" button.

The test will be performed. The parameters will be measured at defined points of time, evaluated, and displayed in a dialog box (see the following illustration).

6 Operation

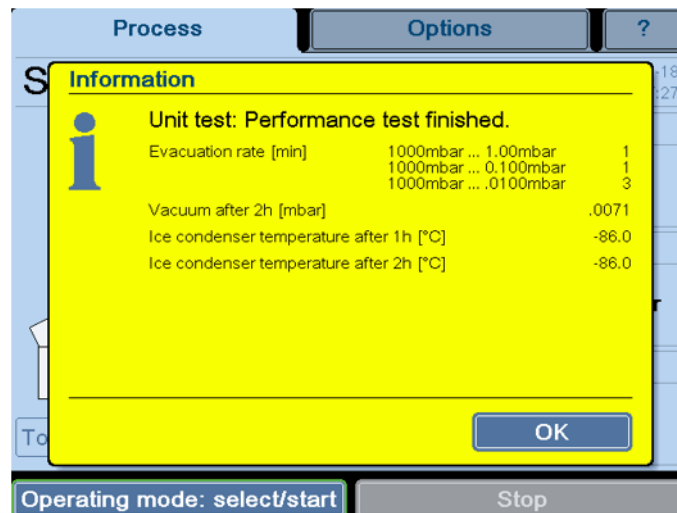

Fig. 29: Results of the performance tests

Evaluation:

Please contact Martin Christ Gefriertrocknungsanlagen GmbH for an assessment of the results.

Option: Leakage test (2)

The leakage test is used to test the chamber of the freeze-dryer for tightness in view of any gaseous or liquid media. Since absolutely tight components simply do not exist, a leak rate is determined.

Procedure:

- In the main window "Process", select the "Set" button to open the dialogue box "Set values: view/edit". Then, select the button "Leakage test".
- Enter the test time (value between 10 min and 18 h) and chamber volume (see the technical data), accept the entries and return to the main window.
- In the main window "Process", select the button "Standard unit test" under "Operating mode: select/start".
- Select "Leakage test" and start the test via the "Run" button.

The parameters for the leakage test have been developed by Martin Christ Gefriertrocknungsanlagen specifically for the freeze-dryers. In a first step, these parameters (vacuum, ice condenser temperature) must be reached. It is not until the conditions are fulfilled that the pressure control valve closes. Then, the actual leakage test is performed in a second step. The result will be indicated by way of a dialogue box.

Evaluation:

The leak rate that is calculated after the test provides information concerning the tightness of the system. If the threshold value is not reached, the test has been passed. If it is exceeded, the test has been failed.

Button "Stop" (8)

Pressing this button stops the current process. The freeze-dryer switches to standby.

6.5.1.2 Main window "Options"

The main window "Options" is where the basic configuration of the control system is defined. It enables the optimum adaptation of the freeze-dryer to its specific area of application.

General

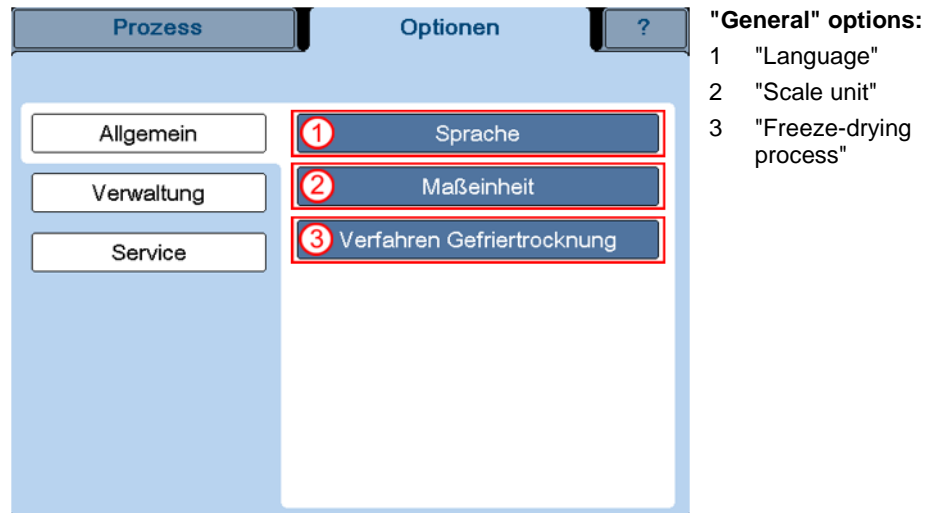

Fig. 30: Overview of the main window "Options/General"

Language (1)

The control system can be used in several languages which can be selected via the dialogue box.

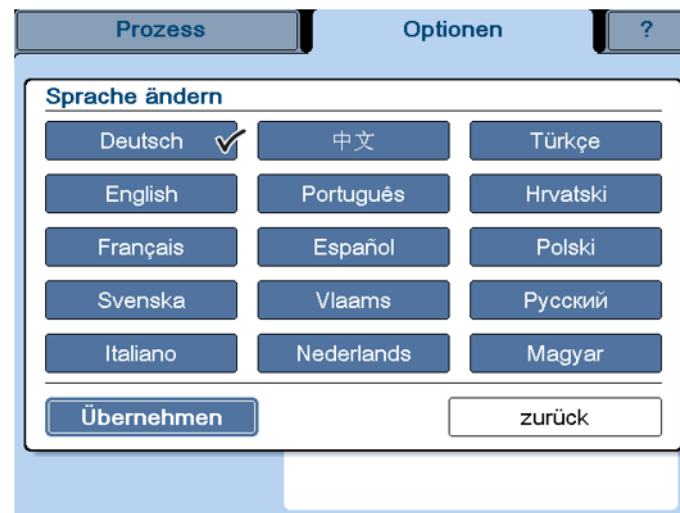

Fig. 31: Dialogue box "Change language"

6 Operation

Scale unit (2)

This dialogue box is used to change the unit of measurement for the temperature and vacuum values.

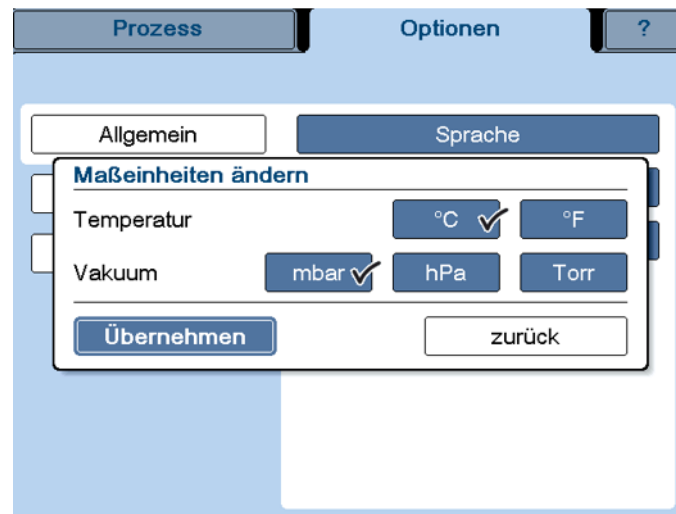

Fig. 32: Dialogue box "Change scale unit"

Freeze-drying process (3)



This function depends on the type of freeze-dryer and is not available for all types.

Prior to the start of the process, the correct process must be selected. The following processes are available:

- → *Cold trap operation*²: Use of the freeze-dryer as a cold trap
- → *Double-chamber method (outside)*: Drying outside the ice condenser chamber
- *Double-chamber method LyoCube*³: Drying outside the ice condenser chamber, but with the CHRIST LyoCube[®] (a rectangular drying chamber that can be loaded from the front)

² Not available for Alpha 3-4 LSCbasic.

³ Not available for Alpha 3-4 LSCbasic.

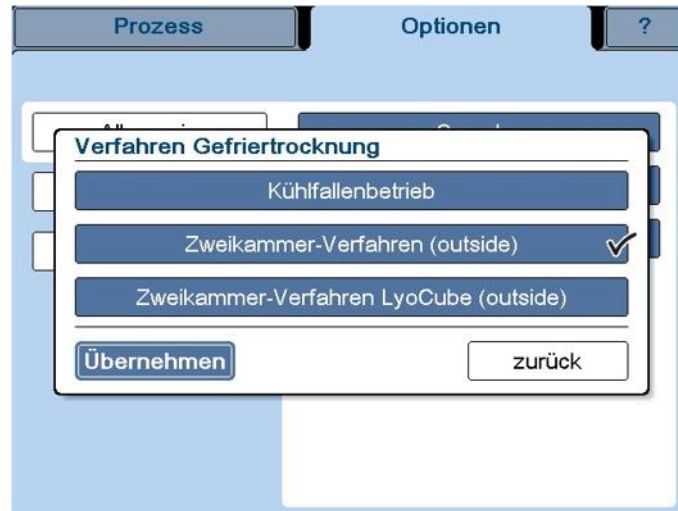

Fig. 33: Dialogue box "Freeze-drying process"

Administration



- "Administration" options:**
- 1 "Date/Time"
 - 2 "Network"
 - 3 "System properties"
 - 4 "Access protection"
 - 5 "Device options"

Fig. 34: Dialogue box "Options" / "Administration"

6 Operation

Date/Time (1)

The control system is equipped with an integrated, battery-buffered clock. After a failure of the buffer battery, the date and time must be reset.



Fig. 35: Dialogue box "Change date/time"

Network (2)

This dialogue box is used to change the network settings.



The changes will not become effective until after a restart of the freeze-dryer.

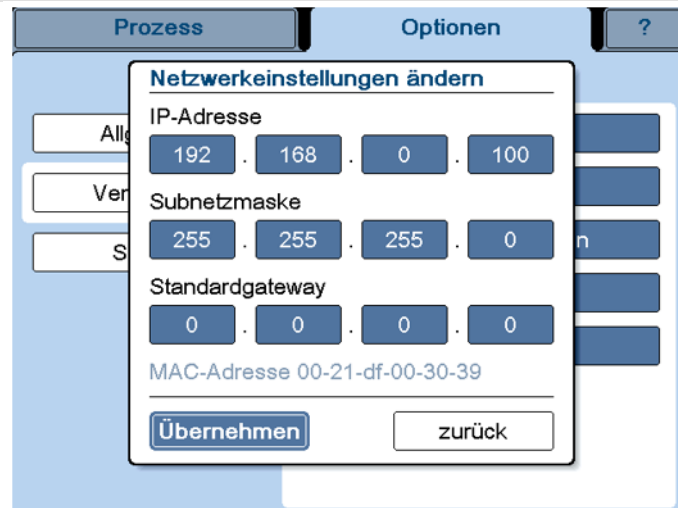

Fig. 36: Dialogue box "Change network settings"

System properties (3)

This dialogue box is used to change the system settings.

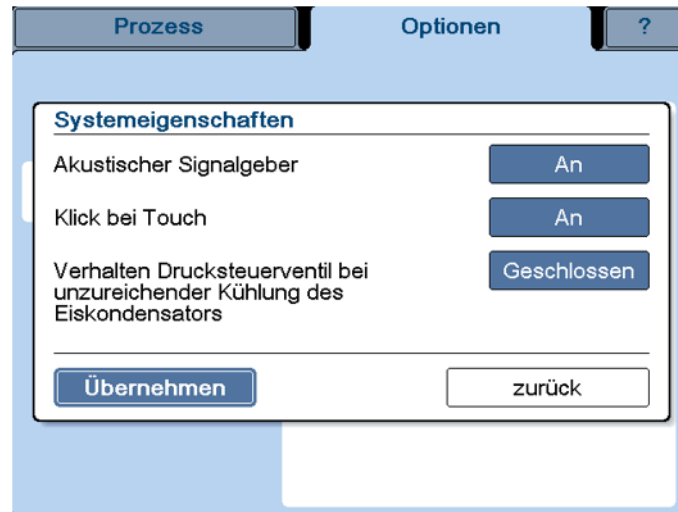

Fig. 37: Dialogue box "System properties"

Beeper: The beeper sounds in the event of a malfunction, for example.

- If the setting is "On", the beeper sounds at intervals of a few seconds until the message is acknowledged.
- If the setting is "Silent", the beeper sounds once when the malfunction occurs.
- If the setting is "Off", the beeper will not sound at all.

Click on touch: If this function is active, a clicking sound can be heard whenever the system registers that a button has been touched.

Behaviour of the pressure control valve in the case of insufficient ice condenser cooling: If this function is active (button "closed"), the pressure control valve will close at an ice condenser temperature of $\geq 20^{\circ}\text{C}$ during the drying process in order to avoid damage to the vacuum pump caused by the withdrawal of condensable gases. Selecting the button again deactivates the function (button "controlled").

6 Operation

Access protection (4)

In this dialogue box, the access rights can be managed on several levels and they can be protected with a password.

In the factory setting with activated access protection, data can be viewed but not edited.



Fig. 38: Dialogue box "Access protection"



The other buttons cannot be activated unless the access protection is active.

Password timer runtime: In order to prevent unauthorised access, the system will automatically switch back to the default setting after a pre-defined period of time.

In this case, there is a small lock symbol in the status line and below this symbol the remaining time until the lock will be active is counted down. At the same time, a button with a big lock symbol will be displayed under the status line.



Fig. 39: Countdown of the password timer and the button with the lock symbol

- The button with the lock symbol blocks any access immediately and the system switches to the default setting.



Fig. 40: Access blocked, data editing not possible

Operator/maintenance/administrator password: For each of these access levels, certain editing rights have been defined. They can be enabled with the corresponding password.

The rights of the various access levels are detailed in the following table.

Action	Operator	Service	Administrator
Editing of the data of the current process run (e.g. selection of the operating mode, changing of set values)	✓	✓	✓
Editing of maintenance functions (e.g. oil change of the vacuum pump)	--	✓	✓
Editing of the default settings (e.g. editing of the access protection configuration, creating and editing of programs, editing of system settings)	--	--	✓

Device options (5)

This dialogue box lists all of the device options that are available for the freeze-dryer in question. A list of all the possible options can be found at chapter 6.6 - "Optional extensions". Options that require a series-number-specific release code are marked with the symbol "Ⓔ".

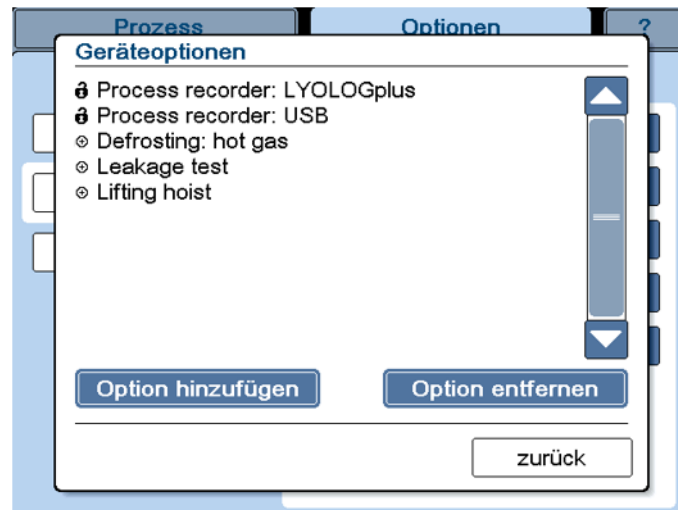

Fig. 41: Dialogue box "Device options" (example)

If the freeze-dryer is to be extended by an option, this option must be enabled via this dialogue box.

- Select the button "Add option". An input window opens.
- Enter the six-digit CHRIST activation code that was supplied for this option. Note that the code is case-sensitive.

Options can be removed in the same way.



The changes will not become effective until after a restart of the freeze-dryer.

6 Operation

Service

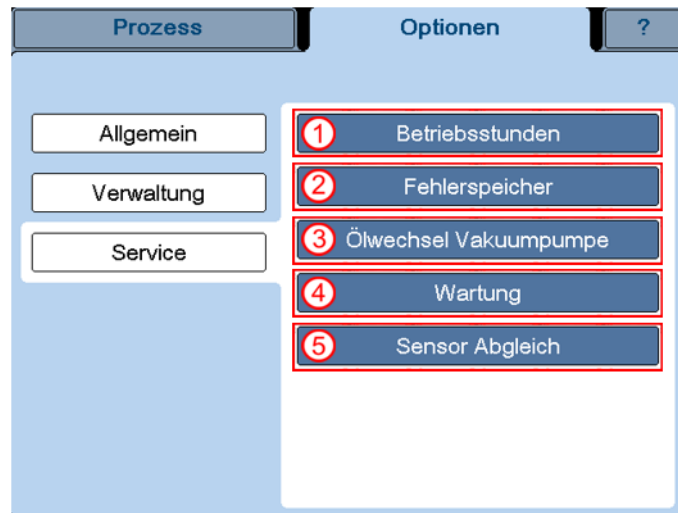

"Service" options:

- 1 "Operating hours"
- 2 "Failure memory"
- 3 "Vacuum pump oil change"
- 4 "Maintenance"
- 5 "Sensor adjustment"

Fig. 42: Dialogue box "Service" (varies depending on the type of freeze-dryer)

Operating hours (1)

This dialogue box is used to view the number of operating hours of the various components of the freeze-dryer, e.g. the refrigeration unit, vacuum pump or pressure control valve. In addition to the name, the respective → *reference designation* is also displayed.

These data are provided for informational purposes only. They cannot be edited.

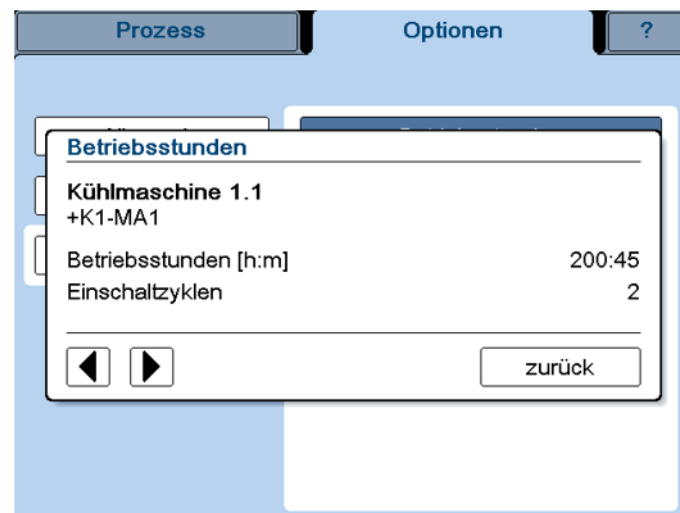

Fig. 43: Dialogue box "Operating hours" (here: refrigeration unit 1.1)

Failure memory (2)

The failure memory stores the most recent messages of the process and equipment information system. The messages can be viewed in this dialogue box. The failure memory includes the last 32 messages. If this number is exceeded, the oldest message will be overwritten.

Use the arrow keys to select the individual messages.

The error message text is always followed by an error code.



Always indicate the error code in the event of enquiries or service requests!

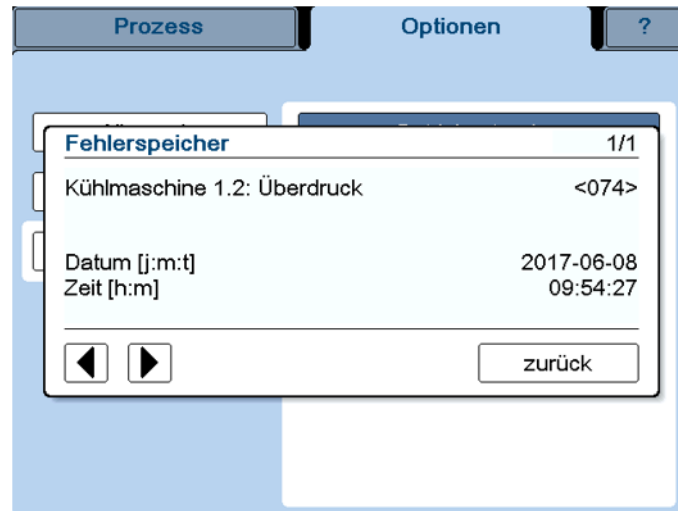

Fig. 44: Dialogue box "Failure memory"

Vacuum pump oil change (3)

The system monitors the oil change interval of the vacuum pump. The interval can be adapted to the vacuum pump model and utilisation.

When the end of an oil change interval is reached, a corresponding message will be displayed.

- Acknowledge the message.
- Change the oil of the vacuum pump.
- Reset the operating hour counter in the dialogue box "Vacuum pump oil change" by way of the "reset" button.



Fig. 45: Dialogue box "Vacuum pump oil change"

6 Operation

Maintenance (4)

The maintenance interval of the freeze-dryer is set at 3,000 operating hours or at least one maintenance per year.

When the end of a maintenance interval is reached, a corresponding message will be displayed.

- Acknowledge the message.
- Make an appointment for the maintenance of your freeze-dryer.
- After the maintenance, our service engineer will reset the operating hour counter in the dialogue box "Maintenance".



Fig. 46: Dialogue box "Maintenance"

Sensor adjustment (5)

In this dialogue box, the sensors are adjusted based on a predefined reference value.



CAUTION

Sensors that are not properly adjusted will lead to incorrect measurements which, in turn, will have a negative effect on the process control.



NOTE

Only specialised personnel are authorised to perform the sensor adjustment.

6.5.1.3 Main window "?"

This main window includes the most important information concerning your freeze-dryer:



- 1 Freeze-dryer type
- 2 Control system type
- 3 Serial number
- 4 Manufacturer contact data
- 5 Details concerning the software version

Fig. 47: Freeze-dryer system information (example)



In the event of enquiries at the manufacturer, please state the data that is stated here.

6.5.2 Starting a freeze-drying process

Freeze-drying processes are started in the main window "Process".



Prior to any freeze-drying process, the correct method must be selected (chapter 6.5.1.2 - "Main window "Options"", "Freeze-drying process (3)").

The set values for the individual process phases ("Freezing", "Warm-up", "Main drying" and "Final drying") are defined prior to the start of the process (see chapter 6.5.2.1 - "Entering set values"). Then, the freeze-drying process can be started via the dialogue box "Operating mode: select/start".



If the freeze-drying process is to be started directly with the "Main drying" phase, the vacuum pump must be warmed up approximately 15 minutes prior to the process start. Failure to do so will result in a corresponding warning message when the process starts.

6 Operation



If the value " ∞ " (infinite) is selected for a process phase, the next phase must be started manually via the button "Operating mode: select/start".

The set values of the active phase can be changed during the process run. In this case, the control system adapts the freeze-dryer to the new set values as quickly as possible.

After the completion of a phase, the freeze-dryer switches to the next phase without switching to standby. The transition from "Freezing" to "Warm-up" takes place automatically. After the completion of the "Warm-up" phase, a dialogue box opens:

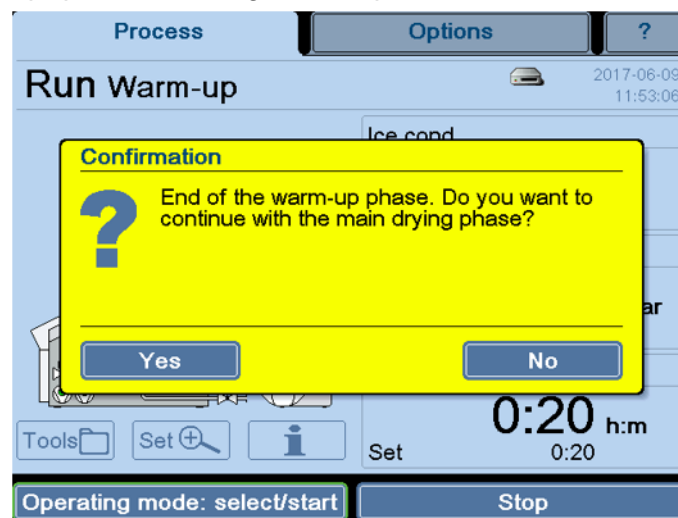

Fig. 48: Dialogue box after the completion of the warm-up phase

The freeze-dryer will remain in the "Warm-up" phase until a confirmation is issued.

Normally, the transition from "Main drying" to "Final drying" takes place automatically.

After the completion of the "Final drying" phase, there will be another enquiry with which the freeze-drying process will be completed. The freeze-dryer remains in the "Run" mode until the enquiry is confirmed.

The process can be stopped any time by way of the "Stop" button. In this case, the freeze-dryer will be switched to standby.

6.5.2.1 Entering set values

The system has stored set values for every phase, and for every value there are pre-defined value ranges that can be determined in the various dialogue boxes by pressing the buttons "min" and "max".

In order to protect the product, a \rightarrow safety pressure value can be entered in every drying section.

Viewing or editing the set values:

- Press the button "Set" (see chapter 6.5.1.1 - "Main window "Process""). The following dialogue box will be displayed:

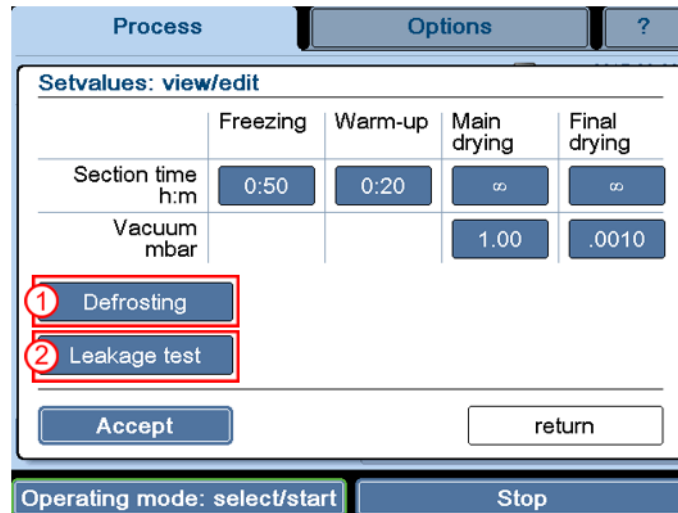

- 1 "Defrosting" button
- 2 "Leakage test" button (option)

Fig. 49: Dialogue box "Set values: view/edit"

Fields that are displayed in the form of buttons can be edited.

- Defrosting (1)
This button is used to pre-define the defrosting time and temperature.
- Leakage test (2)
This button displays the parameters that are used for the leakage test. In addition, the test time and the chamber volume must be stated (depending on the accessories that are used).

Numerical values can be edited with the aid of a numerical keypad:

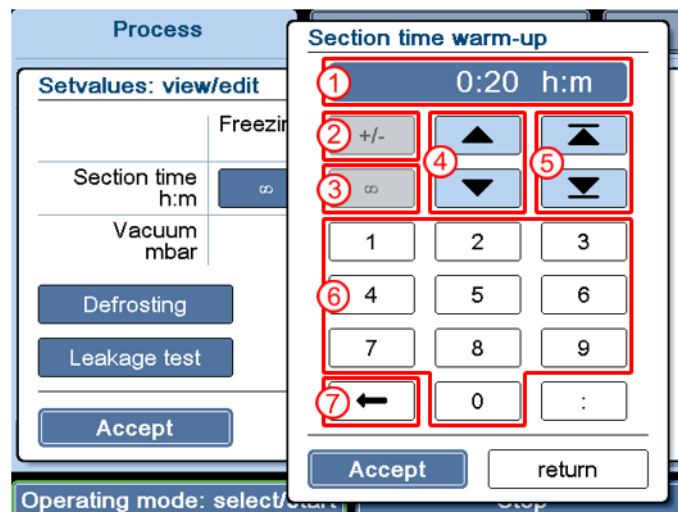

- 1 Set value display
- 2 Button for changing the sign (e.g. when entering temperature values)
- 3 "∞" (infinite)
- 4 Button for editing the value in pre-defined steps
- 5 Selection of a possible maximum or minimum value
- 6 Input of a value via the numerical keypad
- 7 Button for deleting the displayed value

Fig. 50: Editing set values

- Confirm the new value and quit the numerical keypad by pressing the button "Accept".
- Confirm the input and quit the dialogue box via the button "Accept".

i
NOTE

If the dialogue box is closed by the button "return", the changes will be discarded.

6 Operation

6.6 Optional extensions

The basic unit is extendable with the following optional functions:

Leakage test

see also chapter 6.5.2.1 - "Entering set values" and chapter 6.5.1.1 - "Main window "Process"", dialogue box "Operating mode: select/start" (7), button "Standard unit test"

The leakage test enables the chamber of the freeze-dryer to be tested for tightness in view of any gaseous or liquid media. Since absolutely tight components simply do not exist, a leak rate is determined. The parameters for the leakage test have been developed by Martin Christ Gefrier-trocknungsanlagen specifically for freeze-dryers. In a first step, these parameters (vacuum, ice condenser temperature) must be reached. It is not until the conditions are fulfilled that the pressure control valve closes. Then, the actual leakage test is performed in a second step. The leak rate that is calculated after the end of the test provides information concerning the tightness of the system.

USB process recorder

see also chapter 6.5.1.1 - "Main window "Process"", dialogue box "Tools"

This feature enables the recording of a running process on a USB storage medium. After the end of the process recording, the process data can be viewed on the PC with LyoLogplus and be printed. It is also possible to import the data directly into an Excel file.

LyoLogplus data logging software

LyoLogplus is a data logging software program by Martin Christ Gefriertrocknungsanlagen GmbH that is specifically adapted to the requirements of freeze-drying processes. Apart from the graphical representation of the measurement data of currently running processes, it also enables the data export for additional evaluation.

6.7 Switching the freeze-dryer OFF

The freeze-dryer must be in the standby status.

- Switch the freeze-dryer off by pressing the mains switch.

7 Malfunctions and error correction

Malfunctions are displayed in the dialogue box "Process & equipment messages" (see chapter 7.2 - "Process and error messages"). An acoustic signal sounds when an error message is generated.

- Eliminate the source of the problem (see the following chapter).
- Acknowledge the error message.

7.1 General malfunctions

Type of error	Possible reason	Correction
No indication on the display	<ul style="list-style-type: none"> • No power in the mains supply (see chapter 7.1.1 - "Power failure"). • Power cord is not plugged in. • Fuses have tripped. • The mains power switch is set to off. 	<ul style="list-style-type: none"> • Check the mains power supply fuse. • Plug in the power cord correctly. • Check the on-site fuses • Switch mains power switch ON.
The touchpanel does not react at all or it does not react correctly	<ul style="list-style-type: none"> • The sensitivity of the touchpanel is misadjusted. 	<ul style="list-style-type: none"> • Contact the service department (see chapter 7.3 - "Service contact")
The password input fails	<ul style="list-style-type: none"> • The password is not correct. 	<ul style="list-style-type: none"> • Inform the administrator. • If you have lost the administrator password: contact the service department (see chapter 7.3 - "Service contact")
Insufficient vacuum	<ul style="list-style-type: none"> • Incorrect connection of the small flange connection(s). 	<ul style="list-style-type: none"> • Loosen the connection. Place the centring ring with the inner sealing ring in a centred manner between the flange connections and connect it with the clamping ring. Ensure that the centring ring neither slips out of place nor gets jammed.
	<ul style="list-style-type: none"> • Dirty or damaged lid or door seal. 	<ul style="list-style-type: none"> • Clean the lid or door seal and replace it if necessary.
	<ul style="list-style-type: none"> • The ground-in stopper of the attached drying chamber is not installed correctly. 	<ul style="list-style-type: none"> • Grease the ground-in stopper evenly and over the entire sealing surface with vacuum grease.
Leakage in the media drain valve	<ul style="list-style-type: none"> • The media drain valve is soiled with drying residues or wool particles from cleaning cloths. • The O-rings are worn 	<ul style="list-style-type: none"> • Clean the media drain valve (see chapter 8.1.3 - "Aeration valve, media drain valve") and replace it if necessary. • Replace the O-rings.
Leakage in a rubber valve	<ul style="list-style-type: none"> • The valve is soiled. 	<ul style="list-style-type: none"> • Check the valves individually (see chapter 7.1.2.4 - "Rubber valves")

7 Malfunctions and error correction

Type of error	Possible reason	Correction
The displayed vacuum value is not correct	<ul style="list-style-type: none"> • Incorrect calibration • The vacuum sensor is soiled (e.g. due to water residues) • The vacuum sensor is defective. 	<ul style="list-style-type: none"> • Calibrate the vacuum sensor (see the separate operating instructions of the vacuum sensor). • Clean the vacuum sensor. • Check the vacuum display with the aid of a reference device (if available). • see (see chapter 7.1.2.5 - "Vacuum sensor")
The vacuum pump is not activated	<ul style="list-style-type: none"> • See the separate operating instructions of the vacuum pump. 	<ul style="list-style-type: none"> • See the separate operating instructions of the vacuum pump.
Insufficient ice condenser or shelf temperature	<ul style="list-style-type: none"> • The overpressure switch of the refrigeration unit has tripped. • The thermal circuit breaker has tripped. 	<ul style="list-style-type: none"> • Let the unit cool down. • Ensure sufficient air circulation (see chapter 7.1.3 - "Insufficient ice condenser temperature")



NOTE

If it is impossible to eliminate the errors, contact the Christ service department!

7.1.1 Power failure

The control system continues with the process after a power failure. The preselected conditions remain saved even during a process run.

In the event of a power failure in the drying phase, the batch may become unusable. Whether the batch can be saved or not depends on the drying phase in which the product was when the power failure occurred.

- In the final drying phase, the product has reached a residual moisture content of approx. 5%. Below this value, the product is generally not damaged even if the power failure lasts for a longer period of time.
- If the product is in the main drying phase, we recommend aerating the unit, removing the product, and storing it in a deep-freeze. The defrosted condensate must be drained off prior to the next start.

7.1.2 Insufficient vacuum



The vacuum checks must be carried out when the ice condenser is frozen.

7.1.2.1 Small flange connections

Leakages are often due to improper small flange connections between the various components and hose connections or to leakages in the valves.

- Loosen the connection and place the centring ring (with sealing ring inside) in a centred manner between the flange connections.
- Seal the connection with the clamping ring by tightening the wing nut.
- Ensure that the centring ring neither slips out of place nor gets jammed.

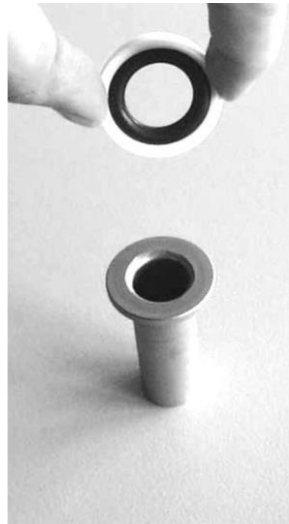

Fig. 51: Small flange and centring ring



Fig. 52: Small flange with centring ring and small flange



Fig. 53: Attaching the clamping ring



Fig. 54: Tightened clamping ring

7 Malfunctions and error correction

7.1.2.2 Aeration valve, media drain valve

A malfunction of the aeration valve or the media drain valve may have several causes. One potential source are contaminants such as product residues within the valve.

- Switch the freeze-dryer off and disconnect the mains plug.
- Clean the valve (see chapter 8.1.3 - "Aeration valve, media drain valve").
- Put the freeze-dryer into operation again.

If there is still a leakage, the freeze-dryer must be checked by qualified specialist personnel (see chapter 7.3 - "Service contact").

7.1.2.3 Pressure control valve

A malfunction of the pressure control valve may have several causes.



NOTE

The inspection of the valve must be carried out by qualified specialist personnel (see chapter 7.3 - "Service contact").

7.1.2.4 Rubber valves

In order to identify a leaking rubber valve, the valves must be checked individually:

- Remove the rubber valve and seal the connection at the drying chamber with a rubber stopper.
- Check the tightness under vacuum until the leaking valve has been localised.
- Clean the valve or replace it if necessary.

7.1.2.5 Vacuum sensor

Vacuum sensors have a limited service life and can be ordered as spare parts.

Functional test:

- Connect the vacuum sensor directly to the suction side connector of the vacuum pump.

If a final pressure of at least 0.011 mbar is reached (with a vacuum pump that has reached its operating temperature), the sensor and the vacuum pump are OK.

7.1.3 Insufficient ice condenser temperature



CAUTION

Ensure sufficient ventilation. Do not place any paper, cloth, or similar material behind or under the unit, since otherwise the air circulation will be impaired.

The refrigeration unit is equipped with a protective device against overpressure in the refrigeration system and with a thermal motor protection switch.

The protective devices trip

- when the ambient temperature is too high
- when the air circulation of the heat exchanger of the refrigeration system is insufficient
- when the refrigeration system is overloaded.

In these cases, the refrigeration unit will be switched off automatically. If the permissible operating conditions are re-established after a cool-down phase of several minutes, the refrigeration unit will be switched on again automatically.

The malfunctions are displayed in the process and equipment information window.

The minimum ice condenser temperature of approx. -55°C or approx. -85°C (depending on the type of freeze-dryer) is reached when the ice condenser is not loaded and the ice condenser chamber is evacuated.

7.2 Process and error messages

The control system displays the complete process and error messages (see chapter 6.5.1.1 - "Main window "Process"", dialogue box "Process and equipment messages"), which is why they are not included in this operating manual.

You can order these documents from our service department.

7 Malfunctions and error correction

7.3 Service contact

In the event of queries, malfunctions, or spare part enquiries:

From Germany:

Contact

Martin Christ Gefriertrocknungsanlagen GmbH
An der Unteren Söse 50
37520 Osterode (Germany)
Tel. +49 (0) 55 22 / 50 07-44 44
E-mail: support.lab@martinchrist.de

Outside Germany:

Contact our agency in your country. All agencies are listed at
www.martinchrist.de → [Sales Partners]



NOTE

If you would like to utilise our after-sales-service, please state the type of your freeze-dryer and its serial number.

8 Maintenance and service

The freeze-dryer and the accessories are subject to high mechanical stress. Thorough maintenance performed by the user extends the service life and prevents premature failure.



CAUTION

If corrosion or other damage occurs due to improper care, the manufacturer cannot be held liable or subject to any warranty claims.

- Use soap water or other water-soluble, mild cleaning agents for cleaning the freeze-dryer and the accessories.
- Do not use corrosive and aggressive substances.
- Do not use solvents.
- Do not use agents with abrasive particles.
- Do not expose the freeze-dryer or its accessories to intensive UV radiation (e.g. sunlight) or thermal stress (e.g. by heat generators).
- Do not turn the unit upside down in order to clean it.

8.1 Maintenance

8.1.1 General

The general state of the freeze-dryer must be checked at regular intervals. Any defects must be eliminated immediately! The following points are of particular importance:

- dirt
- leaks
- corrosion
- bent system components
- loose screw and flange connections
- higher noise levels
- loose cables
- open cable ducts
- missing or illegible safety notes and hazard warnings
- missing or illegible inscriptions on components, pipes (direction of flow) and cables
- etc.

8 Maintenance and service

Cleaning of the freeze-dryer

- Switch the freeze-dryer off by actuating the mains power switch and disconnect the power cord from the wall outlet before cleaning.
- If the freeze-dryer has been contaminated with toxic, radioactive, or pathogenic substances, clean the inside immediately with a suitable decontamination agent (depending on the type of contamination, see chapter 8.2 - "Disinfection of the drying chamber and accessories").
- Remove product residues thoroughly with a cloth.
- Open the lid/drying chamber when the freeze-dryer is not in use so moisture can evaporate.

8.1.2 Ice condenser chamber

Before each start-up, ensure that the ice condenser chamber is free from water residues.

- Open the media drain valve to drain off any liquid. Then, close the valve.
- If necessary, wipe the ice condenser chamber dry with a cloth.

8.1.3 Aeration valve, media drain valve

Contaminants such as product residues may lead to an insufficient vacuum. In this case, the aeration valve and the media drain valve must be cleaned.

- Switch the freeze-dryer off and disconnect the mains plug.
- Remove the valve core.
- Clean the valve core and the opening with a moist cloth.
- Clean the O-rings and inspect them for any damage. Damaged O-rings must be replaced.

- 1 Valve opening
- 2 Valve core
- 3 O-rings

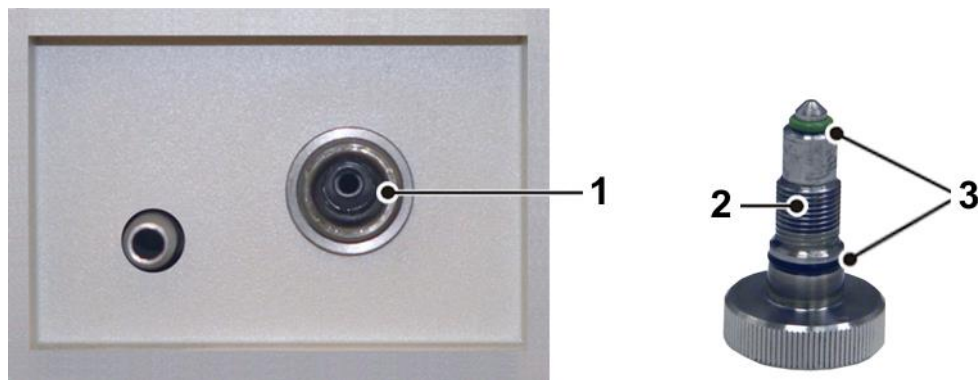

Fig. 55: Valve opening and valve core with O-rings
(example, varies depending of the type of freeze-dryer)

- Reinsert the valve core.
- Put the freeze-dryer into operation again.

If the vacuum is still insufficient, the freeze-dryer must be checked by qualified specialist personnel (see chapter 7.3 - "Service contact").

8.1.4 Heat exchanger (only for air-cooled freeze-dryers)

A lamellar heat exchanger is used for cooling the refrigerant that is compressed by the refrigeration unit. This air-cooled heat exchanger is located at the back of the unit (see chapter 2.1.1 - "Functional and operating elements").

Dust and dirt impair the cooling effect of the air flow. Dust on the lamellas prevents the exchange of heat and, thereby, impairs the performance and power of the refrigeration unit. Strong soiling may cause the unit to fail.

This is why the selected set-up location should be as clean as possible.

- Check the heat exchanger at least once per month for soiling and clean it if necessary.
- Please contact the Christ service department if you have any queries (see chapter 7.3 - "Service contact").

8.1.5 Vacuum pump



NOTE

Please refer to the separate operating manual of the vacuum pump!

The stress of the vacuum pump in conjunction with a freeze-dryer is usually not very high. This is why the recommendations in this operating manual may differ from the information that is provided by the pump manufacturers.

Under normal operating conditions, the following maintenance tasks concerning the vacuum pump must be performed at regular intervals:

- Check the oil level of the vacuum pump once per week. If necessary, top it up with oil.
- Check the running pump for any unusual noise.
- Ensure that the pump has reached its operating temperature prior to changing the oil.
- Perform the first oil change after approximately 100 operating hours.
- The other oil changes depend on the operating conditions. In general, an interval of 500 to 1,000 operating hours is sufficient.
- Please contact the Christ service department if you have any queries (see chapter 7.3 - "Service contact").

8 Maintenance and service

8.1.6 Exhaust filter (oil mist separator)



NOTE

Please refer to the separate operating manual of the vacuum pump and the exhaust filter!

The oil mist that is emitted by the vacuum pump in quantities that depend on the working pressure must be led to the outside or to an exhaust hood or similar. If this is not possible, the pump must be equipped with an exhaust filter (oil mist separator).

- Observe the liquid level in the collecting vessel of the filter.
- Remove the condensate in time (please refer to the information provided by the manufacturer in the separate operating manual).

8.1.7 Vacuum sensor



NOTE

Please refer to the separate operating manual of the vacuum sensor!

The vacuum sensor has only a limited service life. Especially carbon-containing substances, e.g. alcoholic compounds, reduce the service life extremely.

- The vacuum sensor is maintenance-free.
- Remove any soiling on the outside with a cloth.

8.1.8 Accessories



CAUTION

For the care of the accessories, special safety measures must be considered as these are measures that will ensure operational safety at the same time.

Chemical reactions as well as stress-corrosion (combination of oscillating pressure and chemical reaction) can affect or destroy the metal and plastic parts. Barely detectable cracks on the surface can expand and weaken the material without any visible signs.

- Check the material regularly (at least once a month) for
 - cracks
 - visible damage of the surface
 - pressure marks
 - signs of corrosion
 - other changes.

- Replace any damaged components immediately for your own safety.
- Immediately rinse off the accessories if any liquids that may cause corrosion come into contact with them.
- Clean the accessories outside the freeze-dryer once a week or preferably after each use.

8.2 Disinfection of the drying chamber and accessories

- Use commercially-available disinfectants such as, for example, Incidur[®], Meliseptol[®], Sagrotan[®], Buraton[®], or Terralin[®] (available at specialised trade).
- The freeze-dryers and the accessories consist of various materials. A possible incompatibility must be considered.
- Before using cleaning or decontamination agents that were not recommended by us, contact the manufacturer to ensure that such a procedure will not damage the freeze-dryer.
- Please contact us if you have any queries (see chapter 7.3 - "Service contact").



DANGER

If dangerous materials (e.g. infectious and pathogenic substances) are used, the freeze-dryer and accessories must be disinfected.

8 Maintenance and service

8.3 Service



DANGER

In the event of service work that requires the removal of the panels, there is a risk of electric shock or mechanical injury. Only qualified specialist personnel is authorised to perform this service work.

The freeze-dryer is subject to high mechanical stress. In order to be able to withstand this high level of stress, high-quality components were used during the production of the freeze-dryer. Nevertheless, wear cannot be excluded and it may not be visible from the outside.

This is why we recommend having the freeze-dryer checked by the manufacturer during an inspection once per year.

Information and appointments:

From Germany:

Contact

Martin Christ Gefriertrocknungsanlagen GmbH

An der Unteren Söse 50

37520 Osterode (Germany)

Tel. +49 (0) 55 22 / 50 07-44 44

E-mail: support.lab@martinchrist.de

Outside Germany:

Contact our agency in your country. All agencies are listed at www.martinchrist.de → [Sales Partners]



NOTE

If you would like to utilise our after-sales-service, please state the type of your freeze-dryer and its serial number.

8.4 Return of defective parts

Although we exercise great care during the production of our products, it may be necessary to return a unit or accessory to the manufacturer.

In order to ensure the quick and economical processing of returns of freeze-dryers, rotational vacuum concentrators, spare parts, or accessories, we require complete and extensive information concerning the process. Please fill in the following forms completely, sign them, enclose them with the return package, and send them together with the product to:

Martin Christ Gefriertrocknungsanlagen GmbH

An der Unteren Söse 50

37520 Osterode (Germany)

1. Declaration of decontamination

As a certified company and due to the legal regulations for the protection of our employees and of the environment, we are obliged to certify the harmlessness of all incoming goods. For this purpose, we require a declaration of decontamination.

- The form must be filled in completely and signed by authorised specialist personnel only.
- Affix the original form in a clearly visible manner to the outside of the packaging.

**NOTE**

We will return the part/unit if no declaration of decontamination is provided!

2. Form for the return of defective parts

This form is for the product-related data. They facilitate the assignment, and they enable the quick processing of the return. If several parts are returned together in one packaging, please enclose a separate problem description for every defective part.

- A detailed problem description is necessary in order to perform the repair quickly and economically.
- Upon request, we will prepare and submit to you a cost estimate prior to performing the repair. Please confirm such cost estimate within 14 days. If the cost estimate has still not been confirmed after 4 weeks, we will return the defective part/unit. Please note that you must bear the incurred costs.

**NOTE**

The part/unit must be packaged in a transport-safe manner. Please use the original packaging for the unit, if at all possible.
If the product is dispatched to us in unsuitable packaging, you will be charged the cost for returning it to you in new packaging.

The forms can be downloaded online from
www.martinchrist.de → [Service] → [Overhaul, repair and leak testing].

9 Disposal

9 Disposal

9.1 Disposal of the freeze-dryer

Martin Christ Gefriertrocknungsanlagen GmbH is a registered manufacturer of electric and electronic devices that are solely intended for commercial use.

- Comply with all local rules and regulations.

9.2 Disposal of the packaging

- Dispose of the packaging, after having separated the individual materials.
- Comply with all local rules and regulations.

10 Technical data

Manufacturer	Martin Christ Gefriertrocknungsanlagen GmbH An der Unteren Söse 50 37520 Osterode (Germany)	
Type	Beta 1-8 LSCbasic	Beta 2-8 LSCbasic
Part number	102420	102421
Performance data	Beta 1-8 LSCbasic	Beta 2-8 LSCbasic
<u>Ice condenser</u>		
- capacity	8 kg max	8 kg max
- performance	6 kg / 24 h max	6 kg / 24 h max
- temperature	approx. -55°C	approx. -85°C
- chamber volume	approx. 11 l	approx. 11 l
<u>Hot gas defrosting</u>		
- with non-flammable refrigerants:	approx. 5 h	approx. 5 h
- with flammable refrigerants:	approx. 10 h	--
Connection requirements (without vacuum pump and accessories)	Beta 1-8 LSCbasic	Beta 2-8 LSCbasic
Electrical connection:	1 x 230 V / 50 Hz (other supply data on request)	1 x 230 V / 50 Hz (other supply data on request)
Protection class:	I	I
IP protection category according to DIN 60529:	11	11
Apparent power:	0.9 kVA	1.3 kVA
Nominal current:	4.0 A	6.0 A
Mains fuse:	10 A	12 A
Pressure control valve connection:	230 V, 50/60 Hz, 20 VA max.	230 V, 50/60 Hz, 20 VA max.
Vacuum pump connection:	230 V, 50/60 Hz, 4.0 A max.	230 V, 50/60 Hz, 4.5 A max.
Filling quantity	Beta 1-8 LSCbasic	Beta 2-8 LSCbasic
Non-flammable refrigerants:	Filling quantity \triangleq CO ₂ equivalent	Filling quantity \triangleq CO ₂ equivalent
- Isceon 89	600 g \triangleq 2.28 t	--
or	or	8 g \triangleq < 0.01 t
- R290	--	230 g \triangleq 0.87 t
- R404A	400 g \triangleq 1.51 t	76 g \triangleq 1.02 t
- R508B	10 g \triangleq 0.13 t	
Flammable refrigerants:	Filling quantity \triangleq CO ₂ equivalent	
- R1270:	80 g \triangleq < 0,01 t	--
- R170:	8 g \triangleq < 0,01 t	--
Physical data (without vacuum pump and accessories)	Beta 1-8 LSCbasic	Beta 2-8 LSCbasic
<u>Dimensions</u>		
- height	415 mm	415 mm
- width	780 mm	780 mm
- depth	555 mm + 80 mm vacuum connection	555 mm + 80 mm vacuum connection
Weight	approx. 63 kg	approx. 78 kg

10 Technical data

Physical data (without vacuum pump and accessories)	Beta 1-8 LSCbasic	Beta 2-8 LSCbasic
Noise level according to DIN 45635	54 dB(A)	54 dB(A)
EMC according to EN 55011	Class B	Class B
Heat emission	0.6 kW min 1.1 kW max	1.1 kW min 1.6 kW max
Equipment connections	Beta 1-8 LSCplus	Beta 2-8 LSCplus
Vacuum connection	Small flange connection DN25KF (ISO 28403, DIN 2861)	Small flange connection DN25KF (ISO 28403, DIN 2861)
Media drain valve	Hose nozzle DN10 (outside diameter 12 mm)	Hose nozzle DN10 (outside diameter 12 mm)
Aeration valve	Hose nozzle DN6 (outside diameter 10 mm max.)	Hose nozzle DN6 (outside diameter 10 mm max.)
Vacuum sensor	SUB D-9 VCP 63	SUB D-9 VCP 63
Option: data interface (LAN)	RJ 45	RJ 45
Special equipment: water cooling system	Beta 1-8 LSCbasic	Beta 2-8 LSCbasic
Part number	102422	102423
Cooling water consumption	max. 0.16 m ³ /h	max. 0.20 m ³ /h
Heat carried off via the cooling water	1.1 kW	1.6 kW
Cooling water feed flow connection	R3/4" with hose nozzle DN13	R3/4" with hose nozzle DN13
Cooling water return flow connection	R3/4" with hose nozzle DN13	R3/4" with hose nozzle DN13

10.1 Ambient conditions

- The figures are valid for an ambient temperature of +20°C.
- Allowable ambient temperature +10 °C to +25 °C.
- Max. humidity 85% (non-condensing) at +25°C.

10.2 Technical documentation

The technical documentation of this freeze-dryer (e.g. circuit diagram, cooling system) and the safety data sheets of the manufacturers (e.g. for refrigerant) is not attached to this operating manual.

You can order these documents from our service department.

11 Appendix

11.1 Brief operating instructions

Functional and operating elements:

- 1 Ice condenser chamber **Fehler! Textmarke nicht definiert.**
- 2 LSCplus user interface
- 3 Mains power switch



Fig. 56: Total view of the freeze-dryer

- 4 Vacuum sensor
- 5 Pipe connection of the vacuum pump (behind the cover plate)
- 6 Ice condenser

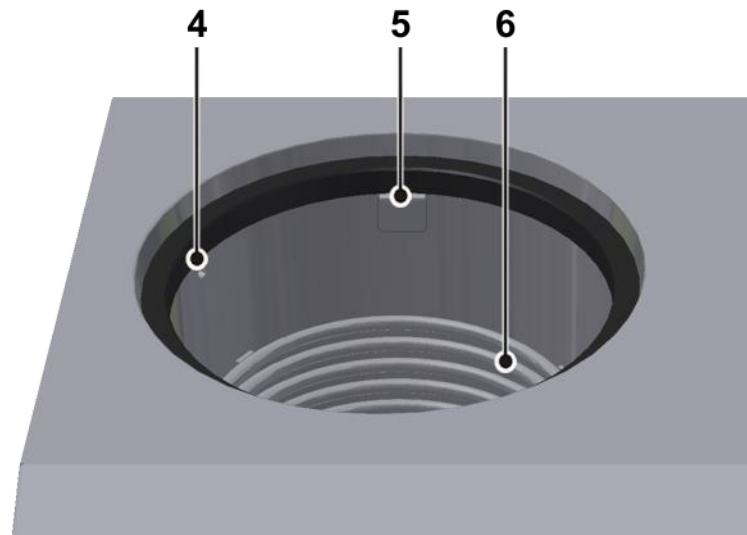

Fig. 57: Ice condenser chamber

11 Appendix

- 7 Aeration valve
- 8 Media drain valve

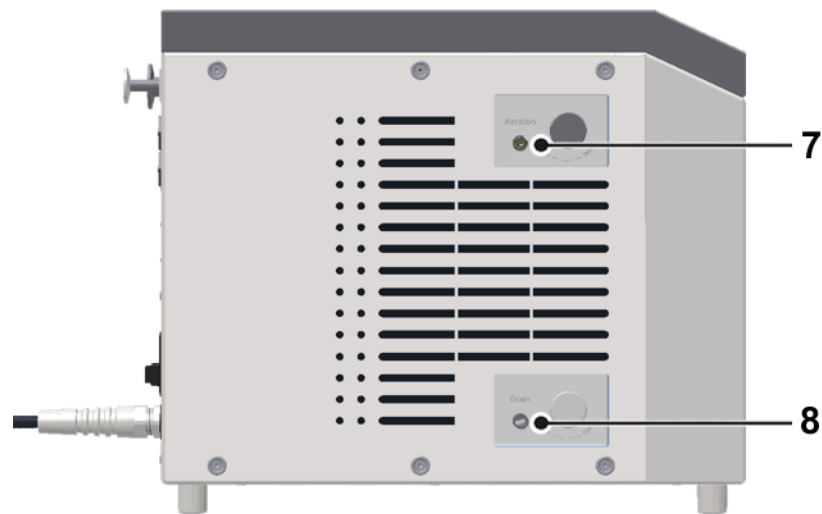

Fig. 58: Left side of the freeze-dryer

- 9 Touchpanel



Fig. 59: User interface with touchpanel

- 10 Heat exchanger of the refrigeration unit
- 11 Name
- 12 Vacuum connection
- 13 Serial interface
- 14 Electrical connection of the vacuum sensor
- 15 Connection of the vacuum sensor
- 16 Power supply of the pressure control valve
- 17 Power supply of the vacuum pump
- 18 Mains fuse
- 19 Mains cable
- 20 Equipotential bonding screw

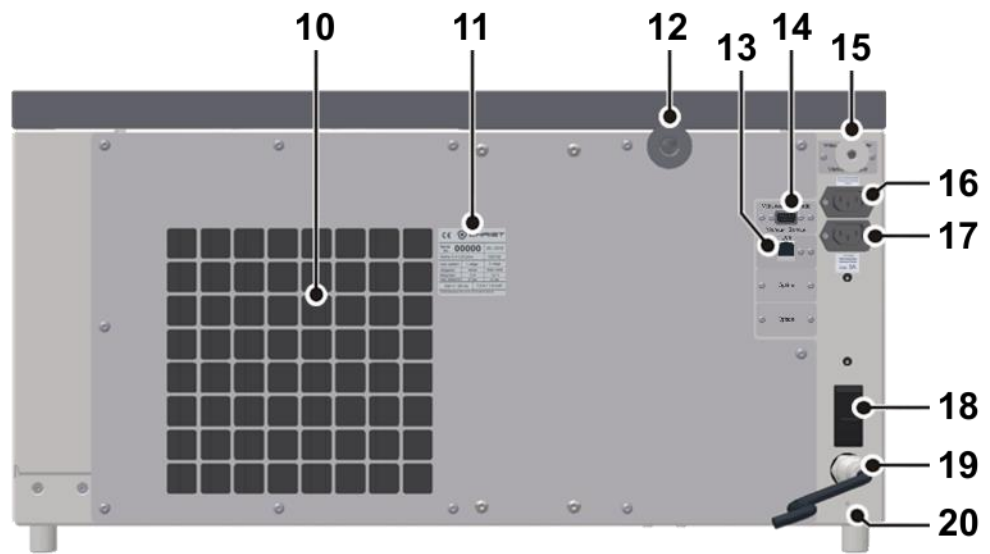

Fig. 60: Rear view of the freeze-dryer

- 1 Status line
- 2 Schematic system diagram
- 3 Values window
- 4 Button "Tools"
- 5 Button "Set"
- 6 Button "Process and equipment messages"
- 7 Button "Operating mode: select/start"
- 8 Button "Stop"

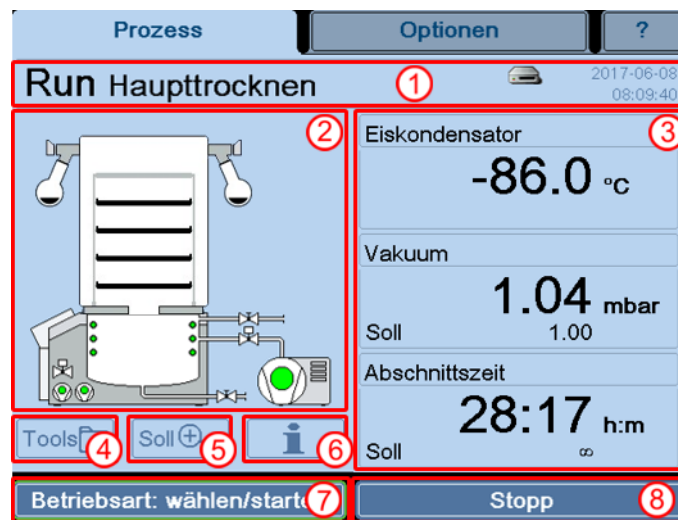

Fig. 61: LSCbasic user interface

Step-by-step instructions – shelf drying

- 1 Freeze the sample separately, e.g. in a deep-freeze.



Ensure that the layer thickness of 1 to 2 cm is not exceeded, since otherwise the drying time needs to be extended.

- 2 Check the ice condenser chamber and ensure that it is completely free from water residues.
- 3 Close the condensate drain valve and install the base plate.
- 4 Switch the unit on 20 to 30 minutes prior to the start of the drying process in order to let the vacuum pump warm up.
- 5 Place the plate rack on the base plate.

11 Appendix

- 6 Transport the frozen samples as quickly as possible from the deep-freeze to the freeze-dryer and place them on the shelves.



NOTE

Recommendation: Store the product vessels on the aluminium shelves or, if possible, the entire rack with the shelves in the deep-freeze. The advantage is that due to the higher cold storage capacity of the aluminium material, the product will remain frozen for a longer period of time so that the sample will not thaw.

- 7 Install the drying chamber. Prior to doing so, check whether the O-ring is completely free of dirt particles. The ground-in stopper of the acrylic glass bell must be greased with high-vacuum grease.
- 8 Ensure that all of the valves of the acrylic glass bell are closed.
- 9 Ensure that the aeration valve is closed.
- 10 Ensure that the condensate drain valve is closed.
- 11 Start the main drying process either by opening the manual shut-off valve or by waiting for the electromagnetic valve to open. Vacuum is applied to the chamber and the freeze-drying process commences.



NOTE

The vacuum pump always runs with maximum power. With this type of freeze-dryer, the power of the vacuum pump cannot be controlled.

- 12 The operating panel displays the vacuum, the ice condenser temperature, and the current operating mode.
- 13 The end of the process is reached when the ice condenser is no longer loaded and when it again reaches a final temperature of approximately -50°C to -54°C. The pressure decreases as a function of the ice condenser temperature.
- 14 Switch the vacuum pump off and aerate the drying chamber via the condensate drain valve or via a rubber valve.
- 15 Switch the unit off by actuating the mains power switch and take the product out of the freeze-dryer.
- 16 Switch the unit on again and start the defrosting process (button "Operating mode: select/start" – "Defrosting").



CAUTION

Ensure that no water gets into the pipe connection of the vacuum pump or vacuum sensor.

- 17 Drain the defrosting water via the condensate drain valve on the left-hand side of the unit. To do so, connect a hose to the hose connector and collect the defrosting water in a suitable vessel.
- 18 Keep the freeze-dryer open (i.e. without the lid or drying chamber) when it is not in use so that moisture can evaporate. This increases the service life of the vacuum sensor.

Step-by-step instructions – drying in a flask

- 1 Freeze the sample separately, e.g. in a deep-freeze.

**NOTE**

Ensure that the layer thickness of 1 to 2 cm is not exceeded, since otherwise the drying time needs to be extended.

- 2 Check the ice condenser chamber and ensure that is completely free from water residues.
- 3 Install the drying chamber. Prior to doing so, check whether the O-ring is completely free of dirt particles. The ground-in stopper of the acrylic glass bell must be greased with high-vacuum grease.
- 4 Ensure that all of the valves are closed.
- 5 Let the vacuum pump warm up 20 to 30 minutes before the freeze-drying processes commences.
- 6 Connect a frozen sample to a valve.

**CAUTION**

After the pressure has fallen below 1.030 mbar, a frozen sample can be connected to a valve. The next frozen sample cannot be connected to another valve until the pressure is again lower than 1.030 bar.

**NOTE**

After the pressure has fallen below 1.030 mbar, a frozen sample can be connected to a valve. The next frozen sample cannot be connected to another valve until the pressure is again lower than 1.030 bar.

- 7 The operating panel displays the vacuum, the ice condenser temperature, and the current operating mode.
- 8 The end of the process is reached when the ice condenser is no longer loaded and when it again reaches a final temperature of approximately -50°C to -54°C. The pressure decreases as a function of the ice condenser temperature.

**NOTE**

The drying time depends on the layer thickness of the sample, the solids content of the sample, and the amount of heat that is supplied during the drying process. In the case of a layer thickness of 1 cm, the freeze-drying process usually takes 24 hours.

- 9 Switch the vacuum pump off and aerate the drying chamber via the condensate drain valve or via a rubber valve.
- 10 Switch the unit off by actuating the mains power switch and take the product out of the freeze-dryer.
- 11 Switch the unit on again and start the defrosting process (button "Operating mode: select/start" – "Defrosting").

11 Appendix



CAUTION

Ensure that no water gets into the pipe connection of the vacuum pump or vacuum sensor.

- 12 Drain the defrosting water via the defrosting water valve on the left-hand side of the unit. To do so, connect a hose to the hose connector and collect the defrosting water in a suitable vessel.
- 13 Keep the freeze-dryer open (i.e. without the lid or drying chamber) when it is not in use so that moisture can evaporate. This increases the service life of the vacuum sensor.

11.2 EC declaration of conformity in accordance with the EC Machinery Directive



EC – DECLARATION OF CONFORMITY

in accordance with the EC Machinery Directive 2006/42/EC, annex II, part 1, section A

The product named hereinafter was developed, designed, and manufactured in compliance with the relevant, fundamental safety and health requirements of the listed EC directives.

In the event of modifications that were not authorised by us or if the product is used in a manner that is not in line with the intended purpose, this declaration will be rendered void.

<i>Product name:</i>	Freeze-dryer
<i>Product type:</i>	Beta 1-8 LSCbasic Beta 2-8 LSCbasic
<i>Order number:</i>	102420, 102422, 102424, 102426, 102428, 102430 102421, 102423, 102425, 102427, 102429, 102431
<i>Directives:</i>	2006/42/EG Machinery Directive 2014/35/EU Low Voltage Directive 2014/30/EU EMC Directive

Martin Christ Gefriertrocknungsanlagen GmbH

An der Unteren Söse 50
37520 Osterode
Germany

Authorised representative
for CE matters:
S. Krippendorff

Osterode, 07/03/2018

M. Christ, Management

11 Appendix

11.3 Declaration of conformity – China RoHS 2



DECLARATION OF CONFORMITY

China RoHS 2 (Administrative Measures for the Restriction of the Use of Hazardous Substances in Electrical and Electronic Products)

Freeze-dryer models: Alpha 1-2 LDplus, Alpha 1-4 LDplus, Alpha 2-4 LDplus, Alpha 1-4 LSCbasic, Alpha 2-4 LSCbasic, Alpha 3-4 LSCbasic, Alpha 1-4 LSCplus, Alpha 2-4 LSCplus, Beta 1-8 LDplus, Beta 2-8 LDplus, Beta 1-8 LSCbasic, Beta 2-8 LSCbasic, Beta 1-8 LSCplus, Beta 2-8 LSCplus, Gamma 1-16 LSCplus, Gamma 2-16LSCplus, Delta 1-24 LSCplus, Delta 2-24 LSCplus

Rotational Vacuum Concentrator models: RVC 2-18 CDplus, RVC 2-18 CDplus HCl-resistant, RVC 2-25 CDplus, RVC 2-33 CDplus, RVC 2-33 CDplus with infrared heating

Christ Gefriertrocknungsanlagen GmbH has made reasonable effort to avoid the use of hazardous substances in the products (freeze-dryers and RVC).

A Product Conformity Assessment (PCA) was performed in order to determine whether the concentration of harmful substances in all homogeneous materials of the component parts is above or below the MCV limit (Maximum Concentration Value limit) as defined in GB/T 26572:

Mercury and its compounds: 0.1 % Cadmium (Cd) and its compounds: 0.01 %
Lead (Pb) and its compounds: 0.1 % Hexavalent chromium (Cr (VI)) and its compounds: 0.1 %
Polybrominated biphenyls (PBB): 0.1 % Polybrominated diphenyl ethers (PBDE): 0.1 %

表1 产品中有害物质的名称及含量
Table 1: Name and content of hazardous substances in the product

部件名称 Component part (PCA)	有害物质 Hazardous substance					
	铅 Lead (Pb)	汞 Mercury (Hg)	镉 Cadmium (Cd)	六价铬 Hexavalent Chromium (Cr (VI))	多溴联苯 Poly-brominated biphenyls (PBB)	多溴二苯醚 Polybrominated diphenyl ethers (PBDE)
Electronic PCB, cables	X ¹⁾	○	○	○	○	○
Display	○	○	○	○	○	○
Housing	X ²⁾	○	○	○	○	○
Base, metal, accessories	X ²⁾	○	○	○	○	○

本表格依据SJ/T 11364的规定编制。
This table is made according to SJ/T 11364.

11 Appendix



O: 表示该有害物质在该部件所有均质材料中的含量均在GB/T 26572规定的限量要求以下。
Indicates that the content of the harmful substance in all homogeneous materials of the component part is below the limit as defined in GB/T 26572.)

X: 表示该有害物质至少在该部件的某一均质材料中的含量超出GB/T 26572规定的限量要求。(企业可在此处, 根据实际情况对上表打“X”的技术原因进行进一步说明。)
Indicates that the content of the harmful substance in at least one homogeneous material of the component part exceeds the limit as defined in GB/T 26572. (Contact the manufacturer for further technical information according to the actual situation.)

1) Contains parts in compliance with exemptions 6c, 7c.I, 7c.II and 37 of 2011/65/EU RoHS.

2) Contains parts in compliance with exemptions 6a, 6b and 6c of 2011/65/EU RoHS.

Apart from the exemptions given in this table, none of the substances listed above have been intentionally added to the product or metallic coatings.

Martin Christ Gefriertrocknungsanlagen GmbH

An der Unteren Söse 50
37520 Osterode
Germany

Osterode, 14/11/2018



General Manager

11.4 EC declaration of conformity in accordance with the Pressure Equipment Directive



EC – DECLARATION OF CONFORMITY

in accordance with the EC Pressure Equipment Directive 2014/68/EU

The refrigeration units in freeze-dryers which are listed hereinafter were developed, designed, and manufactured in accordance with the relevant, fundamental safety and health requirements of the listed EC directives and standards.

In the event of modifications that were not authorised by us or if the product is used in a manner that is not in line with the intended purpose, this declaration will be rendered void.

<i>Product name:</i>	Refrigeration unit in a freeze-dryer
<i>Relevant unit types:</i>	All laboratory systems of the following types: Alpha, Beta, Gamma, Delta Pilot systems of the following types: Epsilon 1-4, Epsilon 2-4 Epsilon 2-6D, Epsilon 2-10D
<i>Max. permissible pressure:</i> <i>Max. permissible temperature:</i>	25 bar 120°C
<i>Directives:</i>	2014/68/EU Pressure Equipment Directive
<i>Underlying standards:</i>	AD 2000 EN 378
<i>Applied conformity assessment procedures:</i>	Module A Category I

Martin Christ Gefriertrocknungsanlagen GmbH

An der Unteren Söse 50
37520 Osterode
Germany

Authorised representative
for CE matters:
S. Krippendorff

Osterode, 23/08/2016



F. Harms, Management

11 Appendix

11.5 Resistance to stress cracking and chemical influences "Plexiglas"



Resistance to stress cracking and chemical influences

PLEXIGLAS® GS

PLEXIGLAS® XT

PLEXIGLAS RESIST® XT

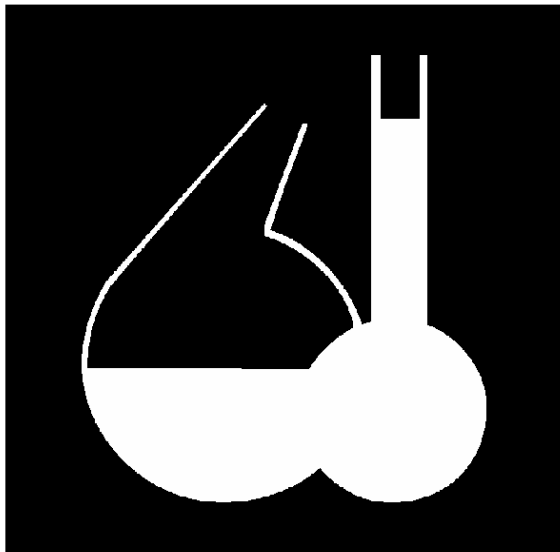

Contents

This brochure provides a summary of the chemical behavior of our semifinished product groups by listing the chemical substances tested on these materials with the aim of assessing their resistance to stress cracking (crazing) and chemical attack.

11 Appendix

Remarks

Brief remarks on the resistance to chemicals other than those listed here, some of them branded products, are made in our leaflet entitled "Chemical resistance of PLEXIGLAS® GS and XT" (Ref. No. 211-1).

The physical properties are described in our Product Description leaflets which your stockist holds available for each group of semifinished material.

When using our products you are advised to observe

- the regional Building Regulations and emission laws,
- the applicable standards
- the product liability to VOB (= Contracting rules for award of public works contracts) and BGB (= Civil Code)
- the guidelines of the employers' liability insurance association and others.

Please consult our current sales ranges to see which semifinished products are available in the market.

Contents	Page
1 Introduction	(varies according to computer and printer settings)
1.1 Chemical resistance	
1.2 Resistance to crazing	
2 Test results	
2.1 Explanation of symbols	
2.2 Listing of results	

1 Introduction

On many occasions, the first question to be asked before choosing PLEXIGLAS® for a particular purpose is whether they are resistant to specific substances or materials. The answer to this question then decides on their use or non-use.

This is normally tested under standard conditions in the laboratory, on the one hand to evaluate the effect of different agents and, on the other hand, to compare the effect of these on different plastics, e.g. PLEXIGLAS®.

1.1 Chemical resistance

The simplest method for investigating such effects consists in bringing the substance concerned into contact with a specimen without applying any additional load, i.e. by immersing the specimen in a liquid or placing a solid substance on its surface. In this context we speak of testing chemical resistance or insensitivity to staining.

Assessment criteria are the changes in appearance, weight and strength after storage. Exposure period, temperature and concentration of the substance in contact with the material have a pronounced influence on results. In order to obtain reliable information, one would have to simulate the conditions in practical use - time, temperature and concentration - most accurately. This effort, however, is only justified in exceptional cases. In order to reduce test periods to a minimum, we increase the test temperature and/or the concentration. In doing so, we rely on our experience that chemical reactions are accelerated at increasing temperatures.

Tests of this type are described in German standard DIN 53 476, 'Determination of the behavior towards liquids' (Fig. 1).

A test period between 1 day, 1 week and 1 month is stated as the time span within which the first changes became visible in the specimen. Short-term testing within 1 minute is performed to identify particularly aggressive substances.

Different types of PLEXIGLAS® show certain variations in chemical resistance. Owing to its increased molecular weight, PLEXIGLAS® GS is somewhat more resistant than PLEXIGLAS® XT or items injection-moulded from PLEXIGLAS® moulding compound. This difference, however, is often very slight, so that the resistance lists for these materials are largely identical.

For more precise information on the chemical resistance of the different grades of PLEXIGLAS® see "2.1 Explanation of symbols."

The test results for chemical resistance apply in particular to permanent exposure of stress-free plastics to the agents mentioned.

Fig. 1: Testing of the chemical resistance to DIN 53 476

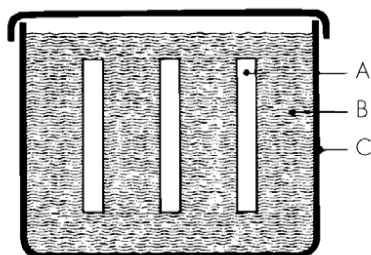

A = specimen
B = agent
C = container

11 Appendix

1.2 Stress cracking (crazing)

Stress provoked by machining, for example, by thermoforming, screwed fastening, riveting, cold curving or local variations in thermal load, must be allowed for in many fields of application. This stress has to be taken into account when evaluating the behavior of PLEXIGLAS®.

Where plastics exposed to air are stressed or strained beyond a specific limit, they will sooner (high stress/strain) or later (low stress/strain) develop crazes. Simultaneous exposure to certain agents may drastically reduce the time span up to the onset of crazing. This phenomenon is termed "environmental stress cracking" or just "crazing."

As can be shown by a simple test, only tensile stress causes cracking: if we bend a PLEXIGLAS® rod between our hands (Fig. 2) and moisten the stressed convex surface with ethyl alcohol, cracks develop within a short time. The same test on the concave lower surface subjected to compressive stress does not cause crazing even after a long time.

PLEXIGLAS® lends itself to various crazing tests, all of them being fairly demanding as far as the preparation and number of specimens, test procedures and testing equipment are concerned.

A further difficulty consists in transferring test results to practical conditions, since many users do not have the necessary experience.

A much simpler test method, the so-called "**bending test**," has been successfully used in our company for over 30 years. The stress conditions it simulates are between those of the tensile creep test and the bending strip method according to DIN 53 499.

The surface of a horizontal test bar, which is held on one side only (Fig. 3), is coated with the test medium and loaded at its free end in such a way that a tensile stress $\sigma_{b,m}$ of no more than 30 MPa is generated near the clamping device. This value decreases linearly towards the loaded end, where it reaches zero. A defined tensile stress is assigned to each point along the surface of the test bar. Crazing sets in at the point of maximum tensile stress and progresses within the test period towards the loaded end, up to a certain point. After a test period of 24 hours at a temperature of 23 °C, the bar is visually inspected for crack propagation. A flexural stress at conventional deflection $\sigma_{b,g}$ is calculated for the end point of crazing.

Long-term experience has shown that products which do not develop crazes after 24 hours at a flexural stress of over 25 MPa and a temperature of 23 °C (and/or at over 15 MPa and a temperature of 50 °C) are not prone to stress cracking in practical use, provided our handling instructions are duly observed.

Fig. 2: Manual test of stress cracking

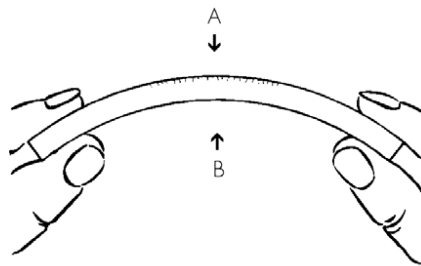

A = tensile stress
B = compressive stress

Fig. 3: Bending test of stress cracking

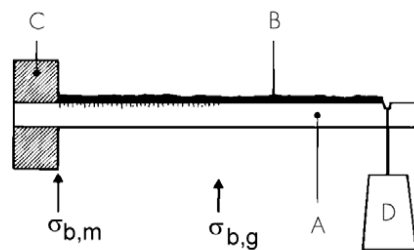

A = specimen
B = agent
C = clamping device
D = load

2 Test results

2.1 Explanation of symbols

With the results stated in the subsequent lists we use symbols and abbreviations that are in need of explanation:

conc =	concentration of the test medium at maximum possible chemical purity or in aqueous solution
mat =	material, i.e. type of semifinished product, from which the test specimens were obtained
233 =	PLEXIGLAS® GS 233; results also valid for GS 215, 218, 221, 222, 231, 238, 1001, 2458 and PLEXIGLAS SOUNDSTOP® GS. Cross-linked, PLEXIGLAS®, e.g. GS 209 and GS SW 235 (sanitary ware grade) shows much higher resistance
XT =	PLEXIGLAS® XT 20070; results also valid for XT 20080, 24370, 21570 AR, MIRROR XT and PLEXIGLAS SOUNDSTOP® XT

11 Appendix

XT-R =	PLEXIGLAS RESIST® XT 41; results also valid for RESIST XT 31 and RESIST XT 21. All RESIST XT grades are more sensitive to chemicals but less prone to crazing than non-modified XT grades.
	Colored PLEXIGLAS® can be expected to behave like the corresponding clear (basic) grades.
RC =	resistance to crazing (Röhm test method 'bending test')
CR =	chemical resistance (similar to DIN 53 476)
EP =	exposure period to the chemical in days; one minute in short-term tests
OE =	overall evaluation , i.e. critical summary of the visual inspections for crazing behavior and chemical resistance

+ = resistant
o = limited resistance
- = not resistant

2.2 Listing of results

Alcohol, mono- and polyhydric

Chemical Conc	Mat	RC	CB	EZ	Evaluation of CR	CR, short-term test	OE
1-Butanol							
100%	233	-	-	28	crazing, swelling	no change	-
100%	XT	-	-	7	pronounced swelling, whitening	no change	-
100%	XT-R	-	-	1	softening, whitening, pronounced swelling	no change	-
1-Hexyl alcohol							
98%	233	-	+	28	no change	no change	o
98%	XT	-	o	28	very slight swelling	no change	-
98%	XT-R	-	-	7	swelling, whitening, dulling	no change	-
1-Methoxy-2-propyl alcohol							
99%	233	-	-	1	pronounced swelling, chemical attack	no change	-
99%	XT	-	-	7	pronounced chemical attack	no change	-
99%	XT-R	-	-	1	specimens dissolved	surface haze	-
n-amyl alcohol							
100%	233	-	o	28	crazing, swelling	no change	-
100%	XT	-	-	28	haze, swelling	no change	-
100%	XT-R	-	-	1	softening, whitening, pronounced swelling	no change	-
Isopropyl alcohol							
100%	233	-	-	7	swelling, crazing	no change	-
100%	XT	-	-	7	swelling, whitening, crazing	no change	-
100%	XT-R	-	-	1	swelling, whitening, dulling	no change	-

Cyclohexanol							
99,5%	233	-	+	28	no change	no change	o
99,5%	XT	-	+	28	no change	no change	o
99,5%	XT-R	-	-	7	swelling, whitening, dulling	no change	-
Ethyl alcohol							
100%	233	-	-	7	softening, swelling	no change	-
100%	XT	-	-	1	swelling	no change	-
100%	XT-R	-	-	1	softening, swelling, whitening	no change	-
50%	233	-	-	7	swelling	no change	-
50%	XT	-	-	1	swelling	no change	-
50%	XT-R	+	-	1	swelling, whitening, dulling	no change	-
Ethylene glycol							
100%	233	-	+	28	no change	no change	o
100%	XT	-	+	28	no change	no change	o
100%	XT-R	-	+	28	no change	no change	o
Ethylene glycol (antifreeze)							
50%	233	+	+	28	no change	no change	+
50%	XT	+	+	28	no change	no change	+
50%	XT-R	+	o	28	slight haze	no change	o
Glycerol							
98%	233	+	+	28	no change	no change	+
98%	XT	+	+	28	no change	no change	+
98%	XT-R	+	+	28	no change	no change	+
Methyl alcohol							
100%	233	-	-	1	softening, swelling	no change	-
100%	XT	-	-	1	softening, swelling	no change	-
100%	XT-R	-	-	1	softening swelling, whitening	slight haze	-
Phenol (dissolved in water)							
5%	233	-	-	1	whitening, tackiness, swelling	no change	-
5%	XT	-	-	1	whitening, tackiness, swelling	no change	-
5%	XT-R	-	-	1	whitening, tackiness, swelling	no change	-

Organic solvents, fuels

Chemical Conc	Mat	RC	CB	EZ	Evaluation of CR	CR, short-term test	OE
Butyl acetate							
99%	233	-	-	1	pronounced swelling, chemical attack	no change	-
99%	XT	-	-	7	pronounced chemical attack	no change	-
99%	XT-R	-	-	1	specimens dissolved	swelling, attack, whitening	-

11 Appendix

Acetic ether (ethyl acetate)							
99%	233	-	-	1	pronounced swelling, chemical attack	no change	-
99%	XT	-	-	1	pronounced chemical attack	surface slightly dull	-
99%	XT-R	-	-	1	specimens dissolved	swelling, chemical attack, dulling	-
Pentyl acetate (amyl acetate)							
98%	233	-	-	28	swelling, chemical attack	no change	-
98%	XT	-	-	28	pronounced chemical attack	no change	-
98%	XT-R	-	-	1	specimens dissolved	slight chemical attack, dulling	-
Acetone							
99%	233	-	-	28	pronounced swelling, chemical attack	no change	-
99%	XT	-	-	1	specimens dissolved	slight chemical attack, slight dulling	-
99%	XT-R	-	-	1	specimens dissolved	swelling, chemical attack, whitening	-
Cyclohexanone							
99%	233	-	-	7	specimens severely attacked	no change	-
99%	XT	-	-	28	pronounced chemical attack	no change	-
99%	XT-R	-	-	1	specimens dissolved	dull surface	-
Diethyl ketone							
99%	233	-	-	1	pronounced swelling, chemical attack	no change	-
99%	XT	-	-	1	pronounced chemical attack	slight chemical attack, slight dulling	-
99%	XT-R	-	-	1	specimens dissolved	swelling, chemical attack, whitening	-
Ethyl methyl ketone							
99,5%	233	-	-	1	pronounced swelling, chemical attack	no change	-
99,5%	XT	-	-	1	pronounced chemical attack	slight chemical attack, slight dulling	-
99,5%	XT-R	-	-	1	specimens dissolved	swelling, chemical attack, whitening	-
Cyclohexane							
99,5%	233	-	+	28	no change	no change	o
99,5%	XT	-	+	28	no change	no change	o
99,5%	XT-R	-	-	28	swelling, whitening	no change	-
Isooctane							
99,5%	233	-	+	28	no change	no change	o
99,5%	XT	-	+	28	no change	no change	o
99,5%	XT-R	-	o	28	slight haze	no change	-

n-Heptane							
99%	233	-	+	28	no change	no change	o
99%	XT	-	+	28	no change	no change	o
99%	XT-R	-	-	28	swelling, colour change to opaque white	no change	-
n-Hexan							
99%	233	-	+	28	no change	no change	o
99%	XT	-	+	28	no change	no change	o
99%	XT-R	-	-	28	swelling, whitening	no change	-
Formamide							
99%	233	-	+	28	no change	no change	o
99%	XT	-	+	28	no change	no change	o
99%	XT-R	-	+	28	no change	no change	o
n-Methylformamide							
99%	233	-	-	7	swelling, haze	no change	-
99%	XT	-	-	1	swelling, chemical attack, whitening	no change	-
99%	XT-R	-	-	1	swelling, whitening, dulling	no change	-
Perchloroethylene (tetrachloroethylene)							
99%	233	-	-	28	dulling, softening of surface	no change	-
99%	XT	-	-	1	swelling, slight chemical attack	no change	-
99%	XT-R	-	-	1	pronounced swelling + chemical attack	no change	-
Shellsol T							
	233	-	+	28	no change	no change	o
	XT	-	+	28	no change	no change	o
	XT-R	-	o	28	slight haze	no change	-
Turpentine substitute							
	233	-	+	28	no change	no change	o
	XT	-	+	28	no change	no change	o
	XT-R	-	-	7	swelling, whitening	no change	-
Turpentine oil DAB 7							
	233	-	+	28	no change	no change	o
	XT	-	+	28	no change	no change	o
	XT-R	-	-	7	swelling, whitening	no change	-
Carbon tetrachloride							
99%	233	-	-	1	swelling, slight chemical attack	no change	-
99%	XT	-	-	1	pronounced chemical attack	no change	-
99%	XT-R	-	-	1	partial dissolution	no change	-
Diesel fuel DIN 51601							
	233	-	+	28	no change	no change	o
	XT	-	+	28	no change	no change	o
	XT-R	-	o	28	colour change to transparent brown	no change	-

11 Appendix

FAM test fuel DIN 51604 A							
	233	-	-	1	pronounced swelling, tackiness	no change	-
	XT	-	-	1	chemical attack, swelling, whitening	slight dulling, slight chemical attack	-
	XT-R	-	-	1	pronounced swelling, chemical attack	haze, chemical attack, swelling	-
FAM test fuel DIN 51604 B							
	233	-	-	1	chemical attack, swelling	slight haze	-
	XT	-	-	1	chemical attack, swelling	haze, chemical attack, swelling	-
	XT-R	-	-	1	chemical attack, swelling, whitening	haze, chemical attack, swelling	-
FAM test fuel DIN 51604 C							
	233	-	-	1	chemical attack, swelling	no change	-
	XT	-	-	1	chemical attack, swelling	haze, whitening, chemical attack	-
	XT-R	-	-	1	chemical attack, swelling, softening	haze, whitening, chemical attack	-
Fuel No. 1 DIN 53521							
	233	-	+	28	no change	no change	o
	XT	-	+	28	no change	no change	o
	XT-R	-	o	28	slight haze	no change	-
Fuel No. 2 DIN 53521							
	233	-	+	28	no change	no change	o
	XT	-	-	28	slight swelling	no change	-
	XT-R	-	-	1	swelling, whitening	no change	-
Petrol, regular (unleaded)							
	233	-	-	28	swelling, yellowing	no change	-
	XT	-	-	7	swelling, dulling, softening	no change	-
	XT-R	-	-	1	swelling, colour change to brown, dulling	whitening of surface, dulling	-
Petrol, regular (leaded)							
	233	-	-	28	colour change to light brown	no change	-
	XT	-	-	28	swelling, colour change to light brown	no change	-
	XT-R	-	-	1	pronounced swelling, softening, colour change to brown	whitening of surface, dulling	-

Petrol, supergrade (unleaded)							
	233	-	-	28	swelling, yellowing	no change	-
	XT	-	-	7	swelling, dulling, softening	no change	-
	XT-R	-	-	1	swelling, colour change to brown, dulling	whitening of surface, dulling	-
Petrol, supergrade (leaded)							
	233	-	-	7	swelling, softening, yellowing	no change	-
	XT	-	-	1	swelling, dulling, softening	no change	-
	XT-R	-	-	1	very pronounced swelling, whitening	whitening of surface, dulling	-
Petroleum							
	233	-	+	28	no change	no change	o
	XT	-	+	28	no change	no change	o
	XT-R	-	o	28	haze, slight yellowing	no change	-

Acids, organic and inorganic

Chemical Conc	Mat	RC	CB	EZ	Evaluation of CR	CR, short-term test	OE
Citric acid							
10%	233	+	+	28	no change	no change	+
10%	XT	+	+	28	no change	no change	+
10%	XT-R	+	o	28	specimens hazy, whitening	no change	o
38%	233	+	+	28	no change	no change	+
38%	XT	+	+	28	no change	no change	+
38%	XT-R	+	o	28	slight haze	no change	o
Formic acid							
5%	233		+	28	no change	no change	
5%	XT		+	28	no change	no change	
5%	XT-R		o	28	slight haze	no change	
Acetic acid							
100%	233	-	-	1	specimens dissolved	no change	-
100%	XT	-	-	1	specimens dissolved	slight chemical attack	-
100%	XT-R	-	-	1	specimens dissolved	pronounced chemical attack, whitening	-
5%	233	+	+	28	no change	no change	+
5%	XT	+	+	28	no change	no change	+
5%	XT-R	+	o	28	specimens hazy, whitening	no change	o
Hydrofluoric acid							
40%	233	-	-	1	swelling, softening, whitening	slight swelling	-
40%	XT	-	-	1	swelling, softening, whitening	very slight dulling, swelling	-
40%	XT-R	-	-	1	swelling, softening, whitening	slight dulling, slight swelling	-

11 Appendix

Lactic acid							
20%	233	-	+	28	no change	no change	o
20%	XT	-	+	28	no change	no change	o
20%	XT-R	-	o	28	haze, whitening	no change	-
90%	233	-	-	7	pronounced swelling, whitening, softening	no change	-
90%	XT	-	-	1	pronounced chemical attack, whitening	no change	-
90%	XT-R	-	-	1	pronounced chemical attack, whitening	no change	-
Oxalic acid							
8,7%	233	+	+	28	no change	no change	+
8,7%	XT	+	+	28	no change	no change	+
8,7%	XT-R	+	o	28	haze, whitening	no change	o
Phosphoric acid							
10%	XT	+	+	28	no change	no change	+
10%	233	+	+	28	no change	no change	+
10%	XT-R	+	o	28	haze, whitening	no change	o
50%	XT	-	+	28	no change	no change	o
50%	233	-	+	28	no change	no change	o
50%	XT-R	+	+	28	no change	no change	+
85%	233	-	-	1	pronounced swelling	no change	-
85%	XT	-	-	1	pronounced swelling, chemical attack	no change	-
85%	XT-R	-	-	1	pronounced swelling, chemical attack	no change	-
Nitric acid							
10%	233	+	+	28	no change	no change	+
10%	XT	+	+	28	no change	no change	+
10%	XT-R	+	o	28	yellowing, haze	no change	o
40%	233	-	+	28	no change	no change	o
40%	XT	-	+	28	no change	no change	o
40%	XT-R	-	-	28	colour change to opaque grey	no change	-
65%	233	-	-	1	very pronounced swelling, softening	dulling, whitening, swelling	-
65%	XT	-	-	1	very pronounced swelling, softening	dulling, whitening, swelling	-
65%	XT-R	-	-	1	very pronounced swelling, softening	dulling, whitening, swelling	-
Hydrochloric acid							
10%	233	+	+	28	no change	no change	+
10%	XT	+	+	28	no change	no change	+
10%	XT-R	+	o	28	whitening, haze	no change	o
32%	233	+	+	28	no change	no change	+
32%	XT	+	+	28	no change	no change	+
32%	XT-R	+	o	28	color change to grey, slight haze	no change	o

Sulphuric acid							
3%	233	+	+	28	no change	no change	+
3%	XT	+	+	28	no change	no change	+
3%	XT-R	+	o	28	whitening, haze	no change	o
30%	233	+	+	28	no change	no change	+
30%	XT	+	+	28	no change	no change	+
30%	XT-R	+	o	1	slight haze	no change	o
98%	233	-	-	1	pronounced swelling, whitening	dulling, whitening, swelling	-
98%	XT	-	-	1	pronounced swelling	dulling, whitening, swelling	-
98%	XT-R	-	-	1	pronounced swelling, reddening	dulling, whitening, swelling	-
Sulphamic acid (amidosulphonic acid)							
18%	233	+	+	28	no change	no change	+
18%	XT	+	+	28	no change	no change	+
18%	XT-R	+	o	28	haze, whitening	no change	o
Tartaric acid							
50%	233	+	+	28	no change	no change	+
50%	XT	+	+	28	no change	no change	+
50%	XT-R	+	o	28	haze, whitening	no change	o
Oleic acid							
99%	233	-	+	28	no change	no change	o
99%	XT	-	+	28	no change	no change	o
99%	XT-R	-	o	28	slight haze, dulling	no change	-

Alkalis

Chemical Conc	Mat	RC	CB	EZ	Evaluation of CR	CR, short-term test	OE
Ammonia solution							
10%	233	+	+	28	no change	no change	+
10%	XT	+	+	28	no change	no change	+
10%	XT-R	+	o	28	whitening (haze)	no change	o
25%	233	+	+	28	no change	no change	+
25%	XT	+	+	28	no change	no change	+
25%	XT-R	+	o	28	whitening	no change	o
Caustic soda solution							
1%	233	+	+	28	no change	no change	+
1%	XT	+	+	28	no change	no change	+
1%	XT-R	+	o	28	haze, whitening	no change	o
10%	233	+	+	28	no change	no change	+
10%	XT	+	+	28	no change	no change	+
10%	XT-R	+	+	28	no change	no change	+
30%	233	+	+	28	no change	no change	+
30%	XT	+	+	28	no change	no change	+
30%	XT-R	+	+	28	no change	no change	+

11 Appendix

Salts, organic and inorganic (saturated solutions)

Chemical Conc	Mat	RC	CB	EZ	Evaluation of CR	CR, short-term test	OE
Aluminium chloride							
42%	233	+	+	28	no change	no change	+
42%	XT	+	+	28	no change	no change	+
42%	XT-R	+	o	28	slight haze	no change	o
Ferric sulphate							
21%	233	+	+	28	no change	no change	+
21%	XT	+	+	28	no change	no change	+
21%	XT-R	+	o	28	haze, whitening	no change	o
Ferric chloride							
48%	233	+	o	28	color change to light brown	no change	o
48%	XT	+	o	28	color change to light brown	no change	o
48%	XT-R	+	o	28	yellowing, haze, dulling	no change	o
Aluminium potassium sulphate							
5%	233	+	+	28	no change	no change	+
5%	XT	+	+	28	no change	no change	+
5%	XT-R	+	o	28	haze, whitening	no change	o
Potassium carbonate							
50%	233	+	+	28	no change	no change	+
50%	XT	+	+	28	no change	no change	+
50%	XT-R	+	+	28	no change	no change	+
Potassium chloride							
25%	233	+	+	28	no change	no change	+
25%	XT	+	+	28	no change	no change	+
25%	XT-R	+	+	28	no change	no change	+
Potassium nitrate							
24%	233	+	+	28	no change	no change	+
24%	XT	+	+	28	no change	no change	+
24%	XT-R	+	o	28	haze, whitening	no change	o
Potassium permanganate							
6%	233	+	+	28	dulling, surface turning brown	no change	+
6%	XT	+	+	28	dulling, surface turning brown	no change	+
6%	XT-R	+	+	28	dulling, surface turning black	no change	+
Potassium sulphate							
10%	233	+	+	28	no change	no change	+
10%	XT	+	+	28	no change	no change	+
10%	XT-R	+	o	28	slight haze	no change	o
Copper sulphate							
17%	233	+	+	28	no change	no change	+
17%	XT	+	+	28	no change	no change	+
17%	XT-R	+	o	28	haze, whitening	no change	o
Magnesium sulphate							
21%	233	+	+	28	no change	no change	+
21%	XT	+	+	28	no change	no change	+
21%	XT-R	+	+	28	slight haze	no change	o
Sodium acetate							
32%	233	+	+	28	no change	no change	+
32%	XT	+	+	28	no change	no change	+
32%	XT-R	+	+	28	no change	no change	+

Sodium carbonate (soda ash)							
2%	233	+	+	28	no change	no change	+
2%	XT	+	+	28	no change	no change	+
2%	XT-R	+	o	28	specimens hazy, whitening	no change	o
20%	233	+	+	28	no change	no change	+
20%	XT	+	+	28	no change	no change	+
20%	XT-R	+	o	28	specimens hazy	no change	o
Sodium chloride (common salt)							
10%	233	+	+	28	no change	no change	+
10%	XT	+	+	28	no change	no change	+
10%	XT-R	+	o	28	haze, whitening	no change	o
Sodium phosphate							
20%	233	+	+	28	no change	no change	+
20%	XT	+	+	28	no change	no change	+
20%	XT-R	+	o	28	slight haze	no change	o
Sodium dihydrogen phosphate							
50%	233	+	+	28	no change	no change	+
50%	XT	+	+	28	no change	no change	+
50%	XT-R	+	o	28	very slight haze	no change	o
Disodium hydrogen phosphate							
8,5%	233	+	+	28	no change	no change	+
8,5%	XT	+	+	28	no change	no change	+
8,5%	XT-R	+	o	28	haze, whitening	no change	o
Sodium hydrogen sulphate							
40%	233	+	+	28	no change	no change	+
40%	XT	+	+	28	no change	no change	+
40%	XT-R	+	o	28	haze, whitening	no change	o
Sodium nitrate							
45%	233	+	+	28	no change	no change	+
45%	XT	+	+	28	no change	no change	+
45%	XT-R	+	o	28	slight haze	no change	o
Sodium sulphate (Glauber's salt)							
25%	233	+	+	28	no change	no change	+
25%	XT	+	+	28	no change	no change	+
25%	XT-R	+	o	28	haze, whitening	no change	o
Sodium chlorate							
49%	233	+	+	28	no change	no change	+
49%	XT	+	+	28	no change	no change	+
49%	XT-R	+	o	28	haze, whitening	no change	o
Sodium thiosulphate							
41%	233	+	+	28	no change	no change	+
41%	XT	+	+	28	no change	no change	+
41%	XT-R	+	+	28	no change	no change	+
Zinc chloride							
50%	233	o	+	28	no change	no change	o
50%	XT	o	+	28	no change	no change	o
50%	XT-R	+	o	28	haze, whitening	no change	o

11 Appendix

Zinc sulphate							
35%	233	+	+	28	no change	no change	+
35%	XT	+	+	28	no change	no change	+
35%	XT-R	+	o	28	haze, whitening	no change	o
Urea							
51%	233	+	+	28	no change	no change	+
51%	XT	+	+	28	no change	no change	+
51%	XT-R	+	+	28	no change	no change	+
Hydroquinone							
6,7%	233	-	o	28	color change to transparent brown	no change	-
6,7%	XT	-	-	28	color change to opaque reddish brown	no change	-
6,7%	XT-R	+	-	28	color change to transparent brown	no change	o

Inorganic compounds

Chemical Conc	Mat	RC	CB	EZ	Evaluation of CR	CR, short-term test	OE
Hydrazine							
15%	233	+	+	28	no change	no change	+
15%	XT	+	+	28	no change	no change	+
15%	XT-R	+	+	28	no change	no change	+
Hydrogen peroxide (hydrogen dioxide, Perhydrol)							
3%	233	+	+	28	no change	no change	+
3%	XT	+	+	28	no change	no change	+
3%	XT-R	+	o	28	haze, whitening	no change	o
30%	233	+	+	28	no change	no change	+
30%	XT	+	+	28	no change	no change	+
30%	XT-R	+	o	28	haze, whitening	no change	o
Sodium hypochlorite							
12%	233	+	+	28	no change	no change	+
12%	XT	+	+	28	no change	no change	+
12%	XT-R	+	o	28	haze, whitening	no change	o
Water, demineralised							
	233	+	+	28	no change	no change	+
	XT	+	+	28	no change	no change	+
	XT-R	+	+	28	no change	no change	+

Organic compounds

Chemical Conc	Mat	RC	CB	EZ	Evaluation of CR	CR, short-term test	OE
Dibutyl phthalate							
99%	233	-	-	28	chemical attack	no change	-
99%	XT	-	-	28	chemical attack	no change	-
99%	XT-R	-	-	1	swelling, chemical attack, whitening	no change	-

Diisobutyl phthalate							
97%	233		+	28	no change	no change	
97%	XT		-	28	chemical attack	no change	-
97%	XT-R		-	28	pronounced chemical attack, haze, crazing	no change	-
Paraffin, liquid							
100%	233	+	+	28	no change	no change	+
100%	XT	+	+	28	no change	no change	+
100%	XT-R	+	+	28	no change	no change	+
Di(2-ethylhexyl) sebacate (dioctyl sebacate)							
	233	-	+	28	no change	no change	o
	XT	-	+	28	no change	no change	o
	XT-R	-	+	28	no change	no change	o
Triorthocresyl-phosphate							
	233	-	+	28	no change	no change	o
	XT	-	-	28	no change	no change	-
	XT-R	-	-	7	chemical attack, dulling	no change	-
Rizinusöl							
	233	-	+	28	no change	no change	+
	XT	-	+	28	no change	no change	+
	XT-R	-	+	28	no change	no change	o
Sojabohnenöl							
	233	-	+	28	no change	no change	o
	XT	-	+	28	no change	no change	o
	XT-R	-	+	28	no change	no change	o
Triethanolamin							
98%	233	+	+	28	no change	no change	+
98%	XT	-	+	28	no change	no change	o
98%	XT-R	+	+	28	no change	no change	+

® = registered trademark

PLEXIGLAS, PLEXIGLAS RESIST and PLEXIGLAS SOUNDSTOP are registered trademarks of Evonik Röhm GmbH, Darmstadt, Germany.

Certified to DIN EN ISO 9001 (quality) and DIN EN ISO 14001 (environment)

This information and all further technical advice is based on our present knowledge and experience. However, it implies no liability or other legal responsibility on our part, also with regard to existing third party intellectual property rights, especially patent rights. In particular, no warranty, whether express or implied, or guarantee of product properties in the legal sense is intended or implied. We reserve the right to make any changes according to technological progress or further developments. The customer is not released from the obligation to conduct careful inspection and testing of incoming goods. Performance of the product described herein should be verified by testing, which should be carried out only by qualified experts in the sole responsibility of a customer. Reference to trade names used by other companies is neither a recommendation, nor does it imply that similar products could not be used.

Ref. No. 211-4 May 2000

Business Unit Performance Polymers
 Evonik Röhm GmbH Kirschenallee, 64293 Darmstadt, Germany.
 info@plexiglas.net www.plexiglas.net www.evonik.com

11 Appendix

12 Glossary

Cold trap operation

Cold traps are used for the condensation of moisture or solvents in combination with vacuum pumps. CHRIST freeze-dryers can be used as cold traps.

Desorption

Desorption (from Latin de-sorbere, sorbere = sup up, suck in) describes a phenomenon whereby molecules are released from the surface of a solid. In order to be able to desorb, the particle must have, or be provided with, a sufficient amount of energy in order to overcome the binding energy.

Double-chamber method

Drying on shelves outside the ice condenser chamber is referred to as a double-chamber system. The advantage compared to the → *single-chamber method* is the considerably higher product capacity. In addition, the product chamber can be isolated from the ice condenser chamber by an intermediate valve in order to perform a → *pressure increase test* for determining the end of the drying process. In freeze-dryers without active shelf cooling, the samples need to be prefrozen externally, e.g. in a deep-freeze or freezer cabinet. After the transfer of the product into the freeze-dryer, the actual → *sublimation* is started.

Eutectic point

The eutectic point is the point at which a homogeneous mixture (e.g. a eutectic alloy) passes directly from the liquid to the solid phase without the formation of a crystal mixture that consists of different phases.

Reference designation

Within the life cycle of industrial systems, a uniform equipment identification system is required for planning, design, implementation, operation, maintenance and dismantling so that all of the objects within the system can be clearly identified at any time. The reference designations (also known as device tags) are affixed to the equipment or components and entered into the technical documents (e.g. circuit diagram).

Safety pressure

Since the vacuum has a dominating influence on the product temperature, Martin Christ Gefriertrocknungsanlagen GmbH has integrated a safety pressure feature into the freeze-dryers in order to ensure the protection of the product. If the pressure inside the drying chamber increases too strongly so that it exceeds the safety limit, the energy supply of the shelves will be interrupted and the sublimation process slows down. This prevents the product from melting.

The safety pressure value that is entered should correspond to a temperature value that is 5°C below the melting point of the product on the vapour pressure curve for ice and water.

12 Glossary

Single-chamber method

(not available for freeze-dryers with an LSCbasic control system)

With the single-chamber method, the freezing as well as the subsequent drying of the product take place inside the ice condenser chamber. The sample is frozen as a result of the low temperature of the ice condenser (-55°C in the case of single-stage systems or -85°C in the case of double-stage systems). During this process, the inside of the chamber can be cooled down to approx. -20°C or -40°C. The moderate supply of the frozen sample with energy, which is necessary during the main drying phase, is ensured by heatable shelves on which the product is placed.

Sublimation

Sublimation (from Latin "sublimis" = high up in the air, raised) is a thermodynamic process of the direct transition of a substance from the solid phase to the gas phase.

13 Index

A

Access protection.....	58
Accessories	11, 31, 76
Accident prevention	23, 24
Acids.....	9, 30
Acids (hazards).....	28
Administration	55
Aeration	36, 64
Aeration valve	13, 37, 82
Aeration valve (cleaning and care).....	74
Aeration valve, malfunction	70
Ambient conditions.....	82
Ambient temperature	36, 82
Apparent power	14, 81

B

Beeper	57
Behaviour of the pressure control valve in the case of insufficient ice condenser cooling	57
Brief operating instructions.....	83
Button "Standard unit test"	51
Button "Stop"	52

C

CE mark in compliance with the directive 2006/42/EC	21
Changing of operating supplies.....	30
Chemical reactions	76
China RoHS 2 – Declaration of conformity. 91	
Circuit diagram.....	82
Cleaning	30
Cleaning agents.....	73, 77
Cleaning of the freeze-dryer.....	74
Cleaning the freeze-dryer and the accessories	73
Click on touch	57
Cold trap operation	54
Commissioning	11
Condensate, contaminated (hazards)	28
Connection.....	31, 37
Connection (hazards).....	25
Connection of the vacuum sensor.....	14
Connection requirements	81

Contaminated condensate (hazards)	28
Contaminated defrosting water (hazards) ..	28
Control system type	63
Cooling system	82
Copyright	10
Corrosion	73, 76
Cost estimate.....	79
Cracks	76
Customer-provided fuses	37

D

Dangerous materials.....	77
Data interface (LAN)	82
Date/Time	56
Declaration of conformity – China RoHS 2. 91	
Declaration of conformity (Machinery Directive).....	10, 90
Declaration of conformity (Pressure Equipment Directive)	93
Declaration of decontamination.....	79
Decontamination agents	77
Defrosting	20, 64
Defrosting water, contaminated (hazards)..	28
Defrosting with hot gas.....	20
Desorption	113
Details.....	49
Details concerning the software version.....	63
Device options	59
Device tag.....	113
Dialogue box "Operating mode: select/start"	50
Dialogue box "Process and equipment messages".....	48
Dialogue box "Schematic system diagram" 46	
Dialogue box "Tools"	47
Dimensions	33, 81
Direct hazard to the life and health.....	22
Disinfectants	77
Disinfection of the drying chamber and accessories	77
Displayed vacuum value is not correct.....	68
Disposal of the freeze-dryer	80
Disposal of the packaging	80
Double-chamber method.....	54, 113

Index

Double-chamber method LyoCube (outside)	54	H	
E		Hazard warnings.....	9, 10
Earth conductor check	29	Hazards (acids).....	28
EC declaration of conformity (Machinery Directive)	10, 90	Hazards (connection)	25
EC declaration of conformity (Pressure Equipment Directive)	93	Hazards (contaminated condensate).....	28
Electrical connection	81	Hazards (contaminated defrosting water)...	28
Electrical connection of the vacuum sensor	14	Hazards (electricity)	26
Electricity (hazards)	26	Hazards (general, transport to commissioning)	24
EMC according to EN 55011	82	Hazards (products, harmful).....	28
End of drying and aeration	19	Hazards (refrigeration system).....	26, 27
Entering set values	64	Hazards (set-up)	25
Environmental protection	24	Hazards (surfaces, cold)	29
Equipment connections.....	82	Hazards (surfaces, hot).....	29
Equipotential bonding screw	14, 29	Hazards (transport)	24
Error correction	67	Heat emission	82
Error messages	29	Heat exchanger	75
Eutectic point	113	Heat exchanger of the refrigeration unit	14
Exhaust filter	40, 76	Hot-gas defrosting.....	20
Explanation of symbols	10	I	
Explanation of the symbols and notes.....	22	Ice condenser	81
External data storage device.....	45	Ice condenser chamber.....	12
F		Ice condenser chamber, cleaning and care	74
Failure memory.....	60	Importance of the operating manual.....	9
Filling quantity.....	81	Important information	22
Final drying	19	Infectious substances	77
Fire prevention.....	31	Informal safety notes.....	24
Form for the return of defective parts	79	Initial start-up	43
Freeze-dryer type.....	63	Inspection by the manufacturer	78
Freeze-dryer, cleaning and care	74	Installation of accessories	43
Freeze-drying of acid-containing products....	9	Insufficient ice condenser or shelf temperature.....	68
Freeze-drying phases	17	Insufficient ice condenser temperature.....	71
Freeze-drying process	18, 54	Insufficient vacuum	67, 69
Freeze-drying process, start	63	Intended use	9
Freezing.....	18	IP protection category according to DIN 60529	81
Functional and operating elements	12	L	
G		Language.....	53
General conditions	10	Layout of the freeze-dryer	12
General information on freeze-drying	15	Leakage in a rubber valve.....	67
General malfunctions	67	Leakage in the media drain valve.....	67
General work (maintenance).....	73	Leakage test	52, 64, 66
		Location of use	36
		LSCbasic control system.....	44

Lyes	30	Operating voltage.....	37
LyoLogplus data logging software	66	Operation	31
M		Operational safety.....	76
Main drying	19	Operator/maintenance/administrator password.....	59
Main window "?"	63	Option: Leakage test.....	52
Main window "Options"	53	Option: USB process recording.....	48
Main window "Process"	45	Optional extensions	66
Mains cable.....	14	P	
Mains fuse	14, 81	Packaging	35, 80
Maintenance	30, 62	Part number	14, 81, 82
Maintenance (general work).....	73	Password input fails	67
Maintenance (vacuum sensor)	76	Password timer runtime	58
Maintenance and service	73	Pathogenic substances.....	74, 77
Malfunction of the pressure control valve ...	70	Performance data	81
Malfunctions.....	67	Performance test.....	51
Manufacturer.....	73, 77, 80, 81	Physical data	81
Manufacturer contact data	63	Potential hazard to the life and health	22
Marking of the unit	21	Potentially hazardous situation.....	22
Max. humidity.....	82	Power failure.....	68
Maximum current for the vacuum pump	40	Power supply	37
Measures to be taken to ensure safe operation	31	Power supply of the pressure control valve	14
Media drain	64	Power supply of the vacuum pump	14
Media drain valve.....	13, 38, 82	Preparation	18, 43
Media drain valve (cleaning and care).....	74	Pressure control valve	41
Media drain valve, malfunction.....	70	Pressure control valve, malfunction	70
Mode of operation	15	Pressure marks.....	76
N		Prevention of accidents.....	9
Name plate	14, 37	Procedures in the event of hazards and accidents.....	30
Network	56	Process and equipment messages	48
Network drive.....	45	Process and error messages	71
No indication on the display	67	Process data.....	45
Noise level	82	Products containing acids	9
Nominal current	81	Products, harmful (hazards).....	28
Nominal voltage	14, 25	Protection class	81
Notes on safety and hazards	9	R	
Notes on transport	34	Radioactive substances	74
O		Rated current	14
Oil mist separator.....	40, 76	Reference designation	49, 60, 113
Operating elements.....	12	Refrigerant.....	81
Operating hours	60	Refrigerant data	14
Operating mode: select/start	50	Refrigeration problems	
Operating personnel	23	Conditions at the location of use	36
Operating state	45	Refrigeration system (hazards)	26, 27

Index

Remaining hazards	32	Status line	45
Resistance to stress cracking and chemical influences "Plexiglas"	95	Step-by-step instructions – drying in a flask	87
Responsibility of the operator	23	Step-by-step instructions – shelf drying	85
Return of defective parts	78	Storage	33
Rubber valves	42, 70	Storage and transport	33
S		Storage conditions	33
Safe operation	31	Stress-corrosion	76
Safety and hazard notes	24	Sublimation	114
Safety area	31	Supply voltage	37
Safety data sheets	82	Surfaces, cold (hazards)	29
Safety devices	29	Surfaces, hot (hazards)	29
Safety distance	25, 36	Switching the freeze-dryer OFF	66
Safety instructions	9, 10	Switching the freeze-dryer on	43
Safety notes concerning set-up and connection	24	System check	29
Safety notes concerning the initial start-up	24	System properties	57
Safety notes concerning the operation	26	T	
Safety notes concerning the transport	24	Technical data	81
Safety pressure	113	Technical documentation	82
Safety-conscious work	23	Thermal stress	36, 73
Scale unit (unit of measurement)	54	Tools	47
Schematic system diagram	46	Topping-up of operating supplies	30
Scope of supply	11	Touchpanel	13
Sensor adjustment	62	Touchpanel does not react	67
Serial interface	14	Toxic substances	74
Serial number	14, 63, 72, 78	Transport	33
Service	60, 78	Transport (hazards)	24
Service contact	72	Transport to commissioning (hazards, general)	24
Service life	73	Type	14, 81
Service work	78	U	
Set process values	48	USB process recorder	66
Set-up	31	USB process recording	48
Set-up (hazards)	25	User interface	44
Set-up and connection	36	UV radiation	36, 73
Signs of corrosion	76	V	
Single-chamber method	114	Vacuum connection	14, 82
Small flange connections	69	Vacuum pump	40
Solvents	30	Vacuum pump connection	81
Solvents	73	Vacuum pump is not activated	68
Special equipment: water cooling system	82	Vacuum pump oil change	61
Specialist personnel	70, 74, 78, 79	Vacuum pump, cleaning and care	75
Standard unit test	51	Vacuum sensor	38, 70, 82
Standards and regulations	10	Vacuum sensor (maintenance)	76
Starting a freeze-drying process	63	Value windows	46

Vapour pressure curve for ice and water.....	
.....	16, 47
Ventilation	71
Vents	36
Viewing or editing the set values.....	64

W

Warranty and liability.....	10
Water cooling system.....	82
Weight	33, 81

Y

Year of manufacture	14
---------------------------	----